

CERN COURIER

International Journal of High Energy Physics

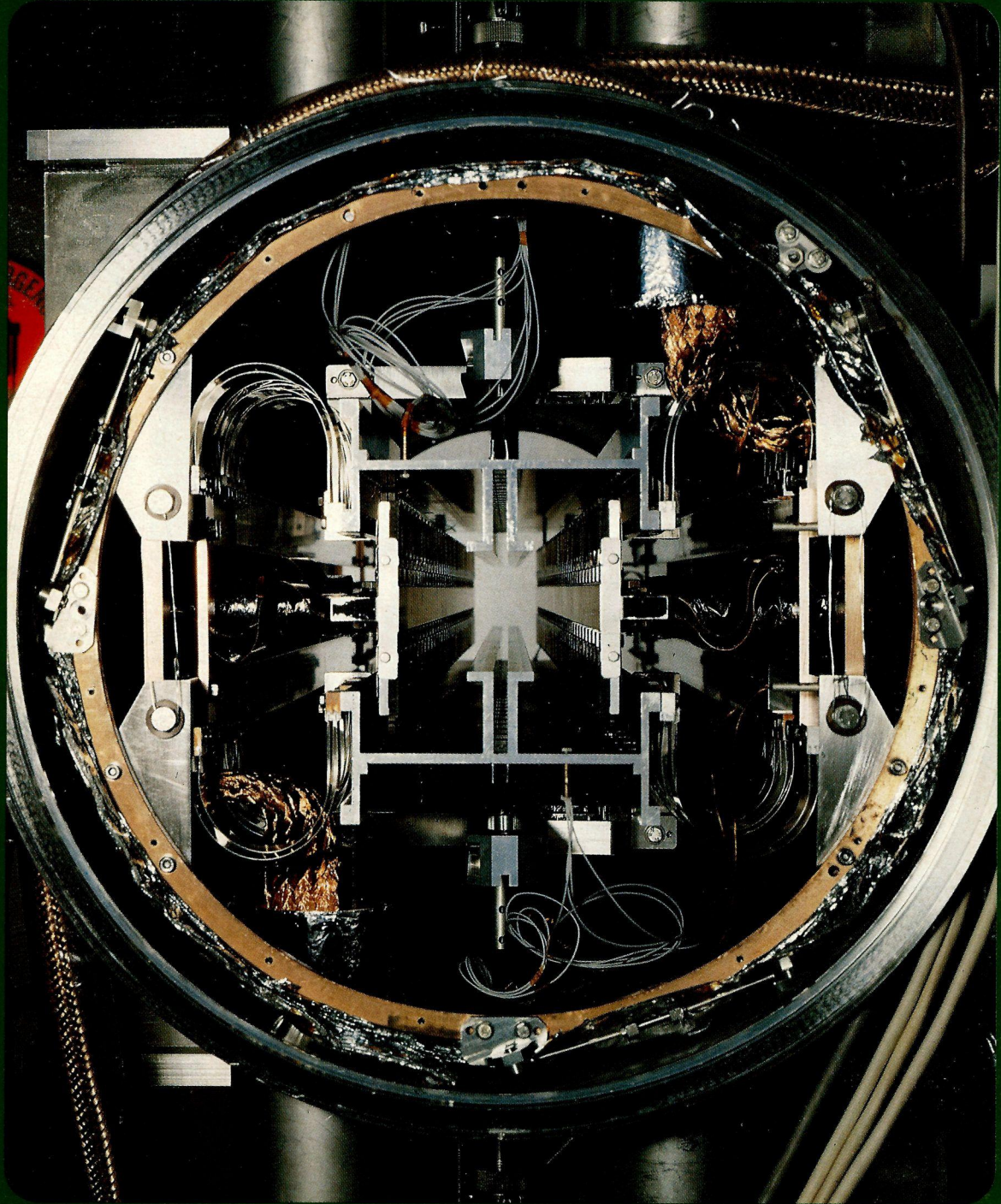

VOLUME 29

JANUARY/FEBRUARY 1989

The World's Biggest Calorimeters...

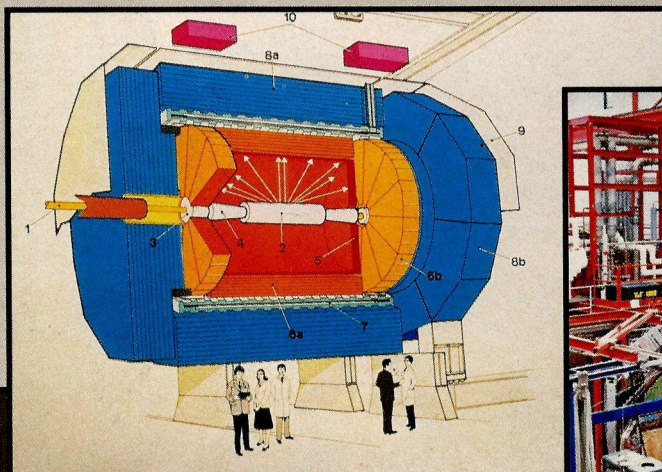

ALEPH LEP/CERN,
Europe



CLEO CESR/Cornell, USA

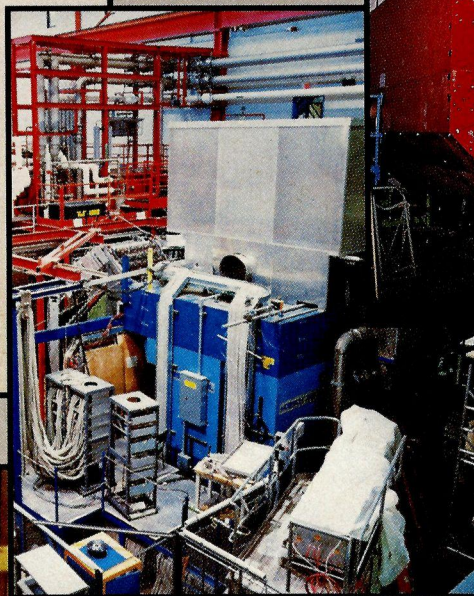

E665 FNAL, USA

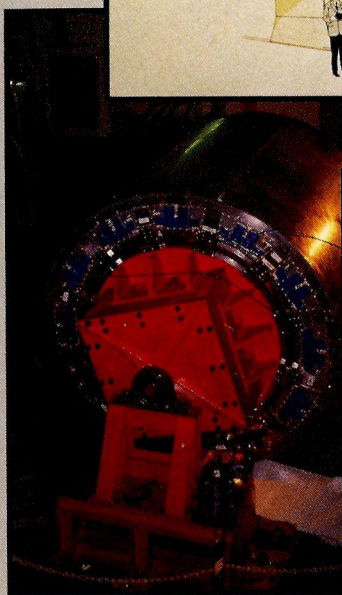

AMY KEK, Japan

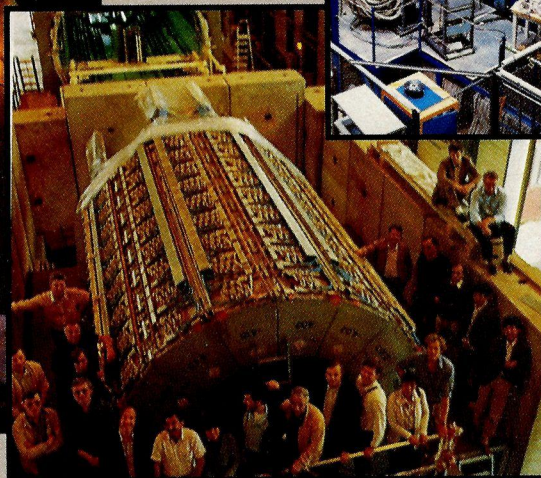

L3 LEP/CERN, Europe

...Use The World's Best ADC's



New FASTBUS Instruments including the 1885F ADC,
2724 24-input preamp and LIFT™ Software Tools

Large calorimeters need economic, high performance ADC's.

LeCroy has been supplying our Series 1880 FASTBUS ADC's to fixed target and colliding beam experiments for over three years. Many particle physics experiments in Japan, Europe and the United States have instrumented or are installing our cost effective systems. These ADC's are part of LeCroy's evolving family of FASTBUS data acquisition electronics for research. Call or write today for a complete FASTBUS Product Summary.

The Series 1880F ADC's feature:

- High Density: 96 chan/#1FASTBUS
- Wide Dynamic Range: to 15 bits
- High Sensitivity: 50 fC/count
- Short Conversion Time: 265 μ sec
- Model 2724 pre-amp compatible
- Fast Readout: 40 megabytes/sec
- Multiple Event Buffer: 8 events
- On-board Calibration: to $\pm 1.5\%$
- Fast Clear: ≤ 600 nsec
- Trigger Outputs: 24 current sums

LeCroy

Innovators in Instrumentation

Advertising enquiries

Europe

Micheline Falciola
Advertising Manager
CERN
CH-1211 Geneva 23, Switzerland
Tel.: +41 (22) 767 4103
Fax: +41 (22) 782 1906

Rest of the world

Tim Serpico
Gordon and Breach Science Publishers
820 Town Center Drive
Langhorne, PA 19047
Tel.: +1 (215) 750 2642
Fax: +1 (215) 750 6343

Distributed to Member State governments, institutes and laboratories affiliated with CERN, and to their personnel.

General distribution

Jacques Dallemagne
CERN, 1211 Geneva 23, Switzerland

In certain countries, copies are available on request from:

China

Dr. Qian Ke-Qin
Institute of High Energy Physics
P.O. Box 918, Beijing,
People's Republic of China

Germany

Gabriela Heessel or Kerstin Techritz
DESY, Notkestr. 85, 22603 Hamburg 52

Italy

Mrs. Pieri or Mrs. Montanari
INFN, Casella Postale 56
00044 Frascati, Roma

United Kingdom

Su Lockley
Rutherford Appleton Laboratory,
Chilton, Didcot, Oxfordshire OX11 0QX

USA/Canada

Cyndi Rathbun (B90904 @ FNALVM)
Fermilab, P.O. Box 500, Batavia
Illinois 60510

CERN COURIER is published ten times yearly in English and French editions. The views expressed in the Journal are not necessarily those of the CERN management.

Printed by: Drukkerij Lannoo nv
8700 Tielt, Belgium

Published by:

European Laboratory for Particle Physics
CERN, 1211 Geneva 23, Switzerland
tel.: +41 (22) 767 61 11,
telex: 419 000 CERN CH,
telefax: +41 (22) 767 65 55

CERN COURIER only:
tel. +41 (22) 767 41 03,
telefax +41 (22) 782 19 06

USA: Controlled Circulation
Postage paid at Batavia, Illinois

Volume 34
No. 1
January/February
1994

CERN COURIER

Covering current developments in high energy physics and related fields worldwide

Editor: Gordon Fraser (COURIER @ CERNVM)*

Production and Advertisements:

Micheline Falciola (FAL @ CERNVM)*

Advisory Board: E.J.N. Wilson (Chairman), E. Lillestol,
H. Satz, D. Treille; with W. Hoogland,
H.I. Miettinen

*(Full electronic mail address... @ CERNVM.CERN.CH)

1 Bridging the centuries
CERN's LHC set to propel physics into the next millenium

Around the Laboratories

6 CERN: Preparing for LEP200/The first CLIC
Two scenarios for higher electron-positron collision energies

7 FERMILAB: Call for physics
New proposals invited for Main Injector

9 SUPERCOLLIDER: Going international

9 KEK/NAGOYA/SLAC: Highly polarized electrons

12 STANFORD (SLAC): Photon theory verified after 40 years

13 BROOKHAVEN: HERA helps RHIC

13 DESY: QCD workshop

16 PSI: Very slow polarized muons

17 GANIL: INDRA and the hot nuclei

18 CERN Accelerator School

Physics monitor

19 Against the grain
Explaining the higgs particle

20 New computing techniques for physics research

22 Elastic scattering: How goes the Odderon ?

22 RICH people: Exploiting Cherenkov radiation

Industry and spinoff

25 CERN: ESPRIT de corps
European programmes for applied data processing

28 People and things

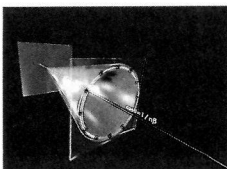

Cover photograph: When high energy particles travel through a transparent substance faster than the 'allowed' velocity of light, so-called Cherenkov radiation is emitted at an angle depending on the particle velocity, in much the same as a shock wave accompanies supersonic aircraft. Knowing the momentum of the particle by magnetic tracking, and measuring the Cherenkov angle of the emitted photons, the mass can be measured in a momentum range where no other technique is so useful. Recent advances in this Ring Imaging Cherenkov (RICH) approach are described on page 22.

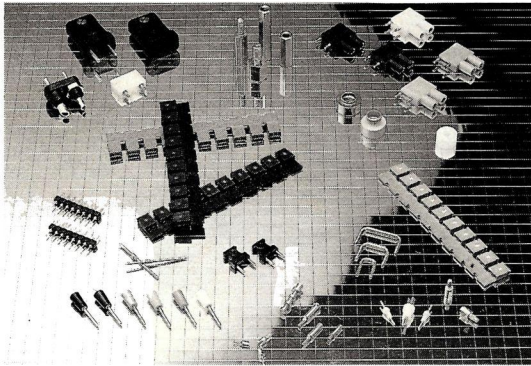

- Terminal pins Jumpers
 - Connectors for chip card readers
 - Fasteners for PC boards
 - Special connectors
- (technical documentation on request)

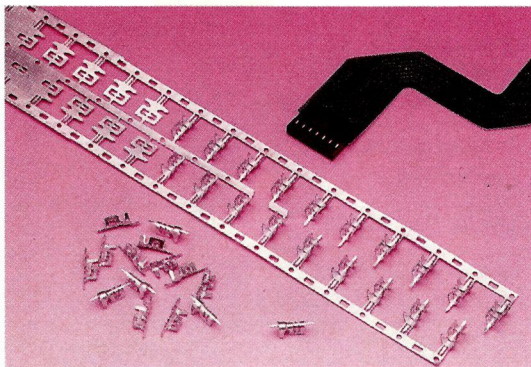

- Coaxial connectors for wire gauge 26
(Available on reels or loose)
- Flexible circuit connectors
(For flexible PCB, Flexcable jumpers, membrane switches)



Screw cutting and small mechanics against drawings
 (Small, medium and high scale production)

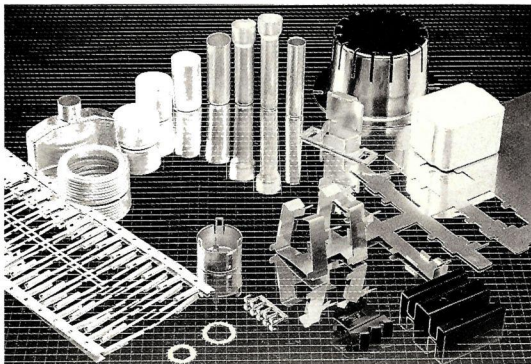

- Cutting off against drawing
- Deep stamping
- Cold drawing
- Extrusion
(Study and of tools performing)

More high-energy physics in **Journal of Physics G: Nuclear and Particle Physics**

- Increased commitment to high-energy particle physics
- Expanded Editorial Board
- Introduction of an Advisory Committee

C J Batty (Rutherford Appleton) · J Cronin (Chicago) · C Detraz (GANIL) · M B Green (London) · M Gyulassy (Lawrence Berkeley) · W D Hamilton (Sussex) · O Hansen (Frankfurt) · J M Irvine (Manchester) · B K Jain (BARC) · I Lovas (Budapest) · G Munzenberg (GSI) · W von Oertzen (Berlin) · R D Peccei (UCLA) · J D Walecka (CEBAF) · C Wilkin (London)

- plus a new series of topical reviews

Cosmic strings, inflationary universe models and the formation of structure by R H Brandenberger (Brown)

Recent developments in string theory by P Ginsparg (Harvard)

Finite temperature field theory by J I Kapusta (Minnesota) and P V Landshoff (Cambridge)

New particles in strong fields? by A Schafer (Caltech)

A new radioactivity by A Sandulescu (Bucharest)

**SPECIAL REDUCED SUBSCRIPTION
 offered to members of any European
 Physical Society.**

For further details and your FREE
 specimen copy, write to

Journals Marketing Department
 IOP Publishing Ltd
 Techno House, Redcliffe Way
 Bristol BS1 6NX, UK



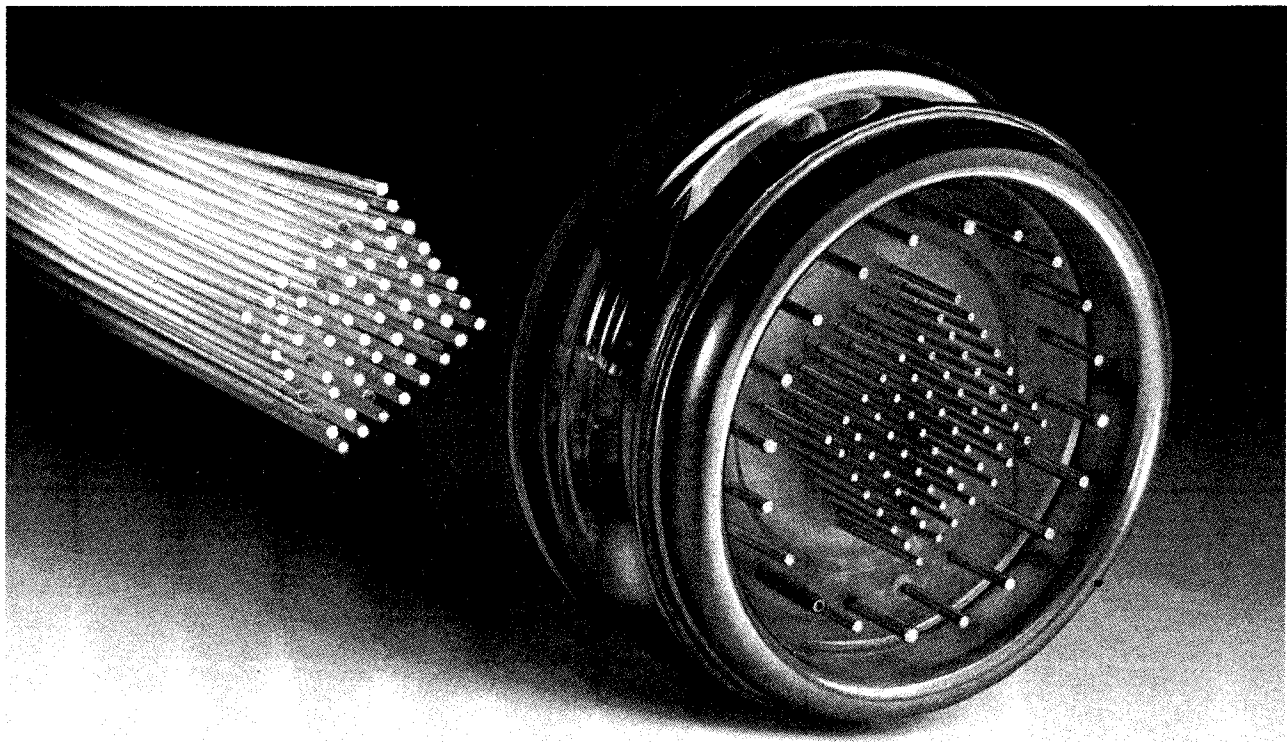

SCINTILLATING FIBRES?

XP4702 reads them out 64 at a time!

First of a new family, the XP4702 extends PMT talents into the realm of spatial as well as time resolution. Combined in a single envelope, 64 ten-stage multipliers with long-life CuBe dynodes produce an 8x8 mosaic of discrete pixels. With uniform channel-to-channel gain and transit-time. The common anode supplies an additional signal that can be used for amplitude analysis or triggering.

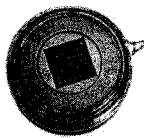

S_{k_e} (λ)	40 mA/W at 400 nm
G	10^6 at 1400 V
t_r	4.8 ns at 1400 V
output	segmented last dynode, 8x8 matrix of 64 independent 2.54 mm x 2.54 mm elements
crosstalk	<5% (scanned by 50 μ m light spot)

XP4702 opens new opportunities in fibre readout, hodoscopy, calorimetry and coarse imaging. Reference: NIM A269 (1988) 246-260.

Fibres courtesy of Optectron, France.
For more information contact: Philips Components, Building BAF2, 5600 MD Eindhoven, The Netherlands. Telex 35000 phtcni/nl jeveo.

STILL SETTING THE STANDARD

Philips Components



PHILIPS

Now in paperback

Speakable and Unspeakable in Quantum Mechanics

Collected Papers in Quantum Philosophy
J. S. BELL

John Bell is one of the leading expositors and interpreters of modern quantum theory. This book contains all of his published and unpublished papers on the conceptual and philosophical problems of quantum mechanics. These have been reset, the references put in order, and minor corrections made.

212 pp. 1988 0 521 36869 3 Pb £8.95 net

Now in paperback

Path Integral Methods in Quantum Field Theory

R. J. RIVERS

This book is a concise graduate-level introduction to analytic functional methods in quantum field theory. After introducing the basic mathematical background, the author goes on to study the varied applications and consequences of the formalism.

Cambridge Monographs on Mathematical Physics
339 pp. 1988 0 521 36870 7 Pb £15.00 net

Now in paperback

Group Structure of Gauge Theories

LOCHLAINN O'RAIFEARTAIGH

'Altogether, the book is a welcome addition to the literature in this field, by a real expert, and will repay the closest study. It is especially an excellent book for graduate students in physics.'

Science
Cambridge Monographs on Mathematical Physics
172 pp. 1988 0 521 34785 8 Pb £9.95 net

Kinetic Theory in the Expanding Universe

JEREMY BERNSTEIN

This is a self-contained exposition of the applications of kinetic theory to basic problems in modern cosmology, such as the role of stable and unstable massive neutrinos and the theory of cosmological helium production. The book begins with a brief survey of the necessary relativity, cosmodynamics and kinetic theory, before going on to discuss specific problems.

Cambridge Monographs on Mathematical Physics
149 pp. 1988 0 521 36050 1 £22.50 net

Differential Geometry, Gauge Theories, and Gravity

M. GÖCKELER and T. SCHÜCKER

A self-contained but concise introduction to modern differential geometry for graduate students and researchers in applied mathematics or theoretical physics working in field theory, particle physics or general relativity.

Cambridge Monographs on Mathematical Physics
248 pp. 1988 0 521 32960 4 £30.00 net

For further information please write to Jacqueline Arthurs at the address below.

Cambridge University Press

The Edinburgh Building, Shaftesbury Road, Cambridge CB2 2RU

ROTA MAG 2000

débitmètre

électromagnétique

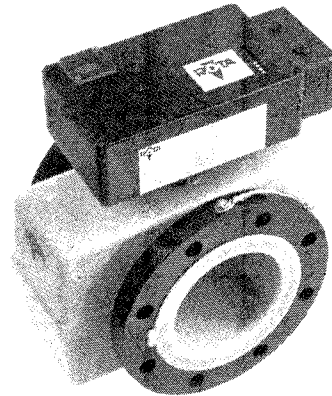

- version compacte
- choix digitale de la plage de mesure
- indication locale
- sécurité intrinsèque

Demandez la documentation

ZIMMERLI MESSTECHNIK AG

Schlossgasse 10 4125 Riehen
061 - 67 54 54

Telex 965 135 Telefax 061 / 67 35 62

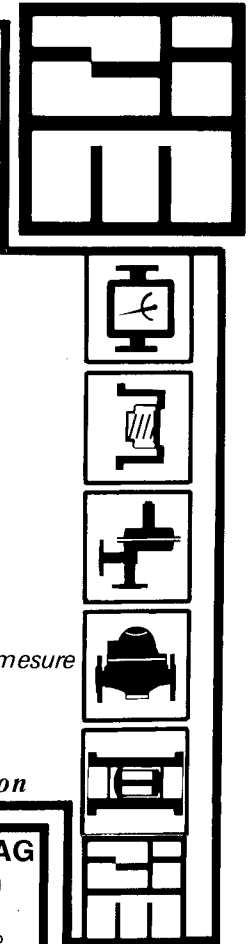

SERVILEC, SOCIÉTÉ ANONYME
POUR LA RÉPARATION D'INSTRUMENTS DE MESURES
17, ch. du Faubourg-de-Cruiseilles
1227 Carouge

**CONFIEZ-NOUS
VOS INSTRUMENTS
DÉFECTUEUX**



**022
43 89 00**

NOUS RÉPARONS ET CALIBRONS :

Oscilloscopes, multimètres, sondes, compteurs, générateurs de fonctions, de fréquences, moniteurs, alimentations, etc...

Dans les marques suivantes :

**Tektronix © - HP © - Fluke © - Schlumberger ©
ABB Metrawatt © - Philips © - Gould ©.**

© marque déposée

CERN 1981-8

At the CERN Council Meeting in December, the Director General traditionally gives an end-of-year review. This time the presentation took on added significance as it marked the end of the eight-year mandate of Herwig Schopper, who handed over on 1 January to Carlo Rubbia.

Looking back over those eight years, Schopper pointed out several major trends. The dramatic growth in CERN 'users' (the scientists coming to the Laboratory to do their research) has led to CERN's research programme becoming really worldwide. The attrition of having to operate an expanding Laboratory under a constant budget has produced in its wake a healthy increase in the efficiency of CERN's big machines and experimental facilities.

For the manufacture of antiprotons, the ground had been prepared at the end of the 1970s, leading to the world's first high energy collisions of proton and antiproton beams in July 1981. The antiproton programme was considerably widened by the arrival of the LEAR low energy antiproton ring the following year.

To consolidate on the historic discovery of the W and Z bosons (the long-awaited carriers of the weak nuclear force) at the big proton-antiproton collider in 1983, a major antiproton improvement programme was launched, aiming to increase both the supply of antimatter and the scope of the experiments.

This culminated in the extraordinary proton-antiproton collision score in the latest run (September-December), tripling the total of the seven previous years combined, and matched by Fermilab in the US (December 1988, page 9). Physics results should not be far off.



In January Carlo Rubbia (right) took over from Herwig Schopper (left) as CERN's Director General. Centre is CERN Council President Josef Rembser.

(Photo CERN 441.12.88)

Turning to other physics, Schopper stressed the effort to measure the basic properties of quarks and leptons, and to test the validity of different possible theories. The availability of higher collision energies (temperatures) has meant that the conditions of laboratory experiments have begun to approach those of the 'Big Bang', postulated as the origin of the Universe, and high energy physics now overlaps astrophysics and cosmology.

The outgoing Director General enumerated some highlights: the limits on the number of neutrino types emerging from the proton-antiproton collider studies; the determination of electroweak parameters in fixed target studies; precision measurements of delicate symmetry (CP) violation in the decays of neutral kaons; the push to find the distribution of quarks and gluons (structure functions) in nuclei using neutrino and muon beams and the resultant discoveries; the new effects found using

high energy ion beams; exotic atom successes at LEAR; and the unexplained 'staggering' of adjacent isotopes of mercury discovered at the ISOLDE isotope separator. These examples reflected the wide range of CERN's research programme, spanning energies from the eV range up to 600 GeV.

Another new trend is the detector development programme, where the stringent demands of physics at tomorrow's colliders has initiated a vigorous R and D effort, already producing its first fruits.

Turning with evident pleasure to the construction of the LEP electron-positron collider, Schopper sketched how planning for this giant machine had started early, with the first ideas being tabled in 1976. A series of in-depth design studies brought modifications in both machine design and location, with Council finally approving in October 1981 a 'stripped down' version, to be built under a budget reduced from the originally pro-

A new European plan to attack cancer

posed figure and held constant over a stretched construction period. With the necessary civil engineering authorizations in hand in the summer of 1983, the huge civil engineering operation was launched.

With installation now going very well and following the success of the initial injection studies in July, Schopper looked forward to the first electron-positron collisions, hoping for 50,000 Z particles by the end of 1989. (The Z, the electrically neutral carrier of the weak nuclear force, was discovered at CERN in 1983. So far, only the high energy proton-antiproton colliders at CERN and Fermilab provide enough energy to manufacture these particles – some 400 having been accumulated in five years.)

Moving from physics to management, Schopper showed how CERN's map of Member States now covers Spain and Portugal. The task of LEP construction had brought about major reorganizations – new divisions have been set up and large amounts of manpower transferred. New technical boards coordinate common interests across the divisional structure, while technology transfer and relations with industry have been given increased importance.

In thanking everyone for their help during a sometimes difficult period and in wishing his successor continuing success, Schopper reminded his audience of the 'CERN spirit', born during the foundation of the Organization, which has fostered CERN's competitiveness, while ensuring fairness, priority of scientific and technical goals against national or personal interests, and tolerance and respect for different cultures and attitudes.

While cancer remains the scourge of mankind, a large proportion of cases these days are amenable to treatment by irradiation. Bringing new irradiation centres to large concentrations of population is thus a vital task. This was highlighted at the first three-day workshop of the European Light Ion Medical Accelerator (EULIMA) project to assess the potential value of light ion beam therapy. Held in November at the Antoine-Lacassagne Centre, Nice, one of twenty cancer centres in France, the workshop was attended by some 60 delegates from Europe, USA, Canada and Japan, representing the fields of physics, radiobiology, radiotherapy and medicine.

The European accelerator initiative goes back to October 1985, the result of a proposal at a meeting of the heavy particle group of the European Organization for Research and Treatment of Cancer (EORTC). A preliminary EULIMA

meeting at CERN in March 1986 defined the project aims (March 1987, page 25). In spring 1988, financial support from the Committee for the European Development of Science and Technology (COD-EST) enabled experts in the field (mainly from Louvain-la-Neuve, Liverpool and Nice) to get together. Subsequently the Commission of the European Communities funded the workshop in the framework of its 4th Medical and Health Research Programme, in parallel with the

At the recent EULIMA workshop in Nice, Mark Philips (Berkeley) showed how light ions and protons can be used other than for cancer therapy, for example against a surgically inaccessible arterial problem in the vicinity of the brain – intracranial arteriovenous malformation (AVM). Top left, the untreated AVM is the black mass in the centre of the photo; top right, after the beam therapy the AVM is smaller; bottom left and right, the arterial system to the brain has almost resumed its normal pattern.

(Photo M. Philips, Berkeley)

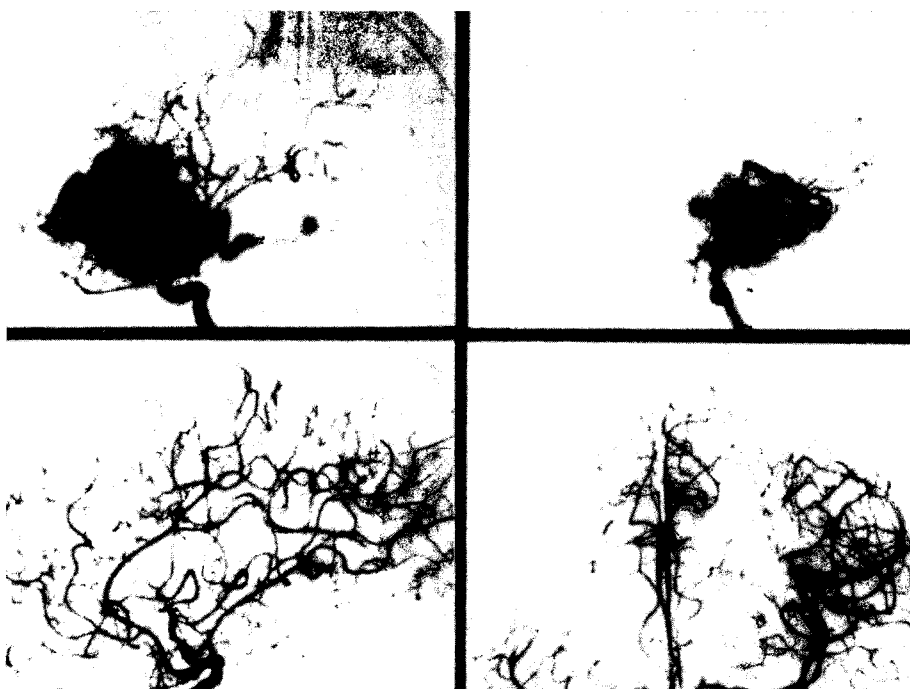

STR330 CERN Host Interface and Processor System - CHIPS -

The STR330 CHIPS aims to provide:

- * Modular and versatile state of the art interfacing between FASTBUS segments and DECworld, VMEworld, PCworld, ...-world.
- * High performance, general-purpose FASTBUS processing.

A user is able to adapt or vary his actual system configuration depending on his requirements:

- * FASTBUS to VAX-BI-bus interface
- * FASTBUS to DEC Q-bus interface
- * FASTBUS to VMEbus interface
- * High-level trigger processor
- * Supervising controller
- * Front-end multiprocessing

A system consists of a single-width FASTBUS processor board which contains elements that are necessary in either application, and a couple of add-on, daughter or auxiliary boards. The diagram gives a system overview.

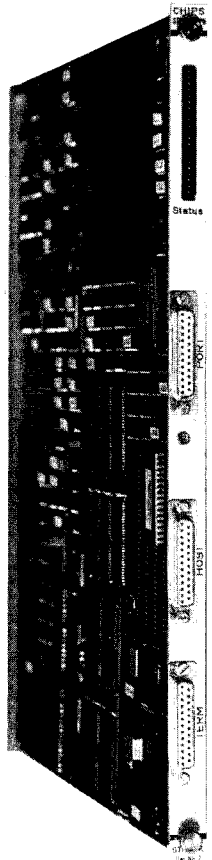
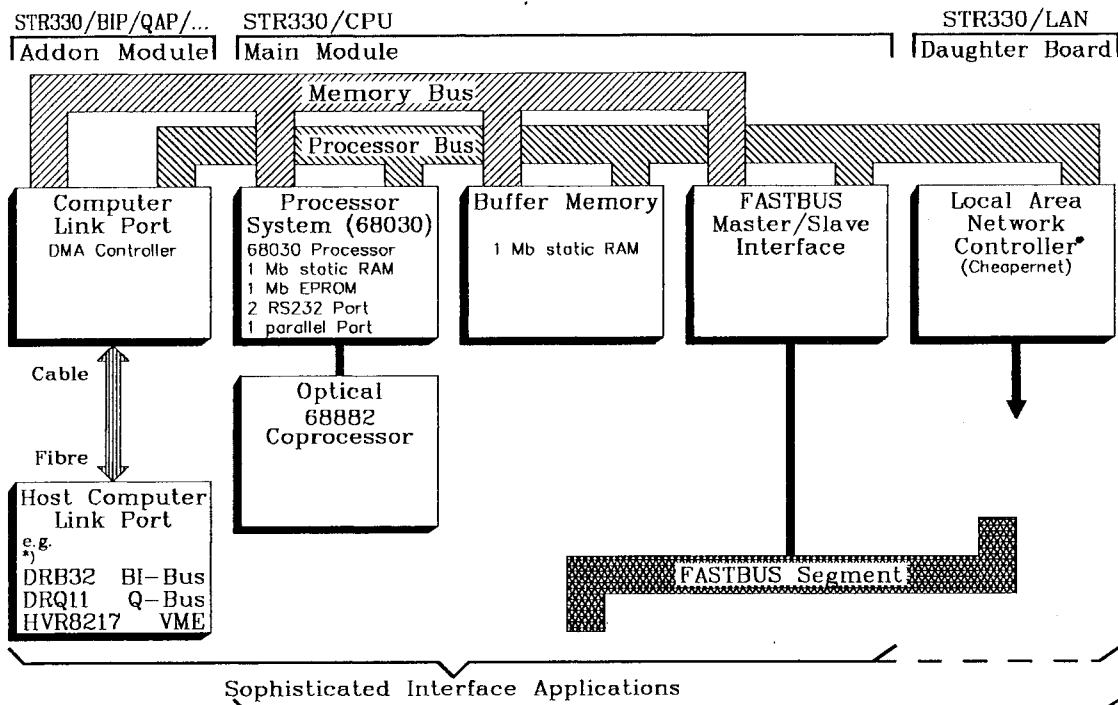

*) DRB32, DRQ11 are devices from DEC
DVR8217 is a module from CES

General Purpose FASTBUS Processor Applications

STR331 Optical Data Interconnect - ODI - for DEC DRB32 Compatible Devices

The STR331^{**) ODI} is designed to allow high speed point to point interfacing between two DEC DRB32 IO-register compatible IO-ports, separated by distance of up to several kilometers, with very high reliability.

Applications:

- * Long distance connection of a DEC VAX host computer located in a control room and a STR330 CHIPS FASTBUS interface or a STR501 AEB/EVI located down an experimental pit.
- * Long distance connection of two DEC VAX machines in a point to point arrangement utilising all advantages of an optical transmission system.

^{**) joint development of CERN, LIP(Portugal)}

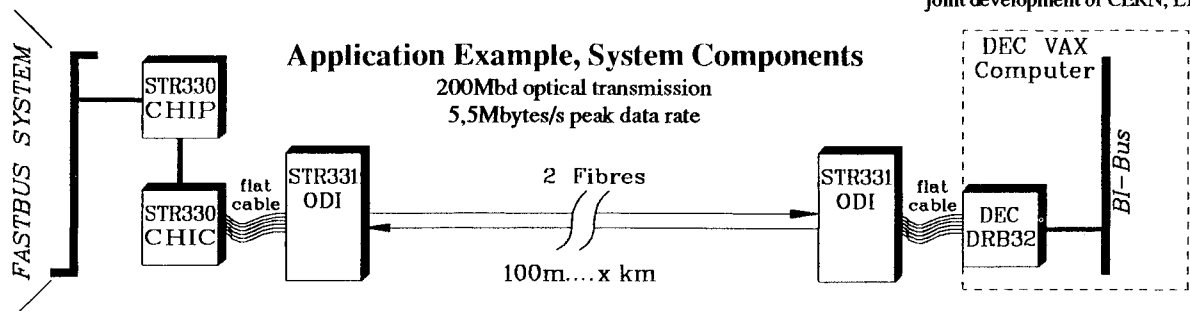

D-2000 Tangstedt, P.O.Box 1147, W-Germany
 Telefon (04109) 55-0 Telefax (04109) 5533 Telex 2 180 715 TEGS



Commission's 'Europe against cancer' programme.

Protons and ions

Why protons and light ions?

Conventional therapy techniques, such as X-rays (typically 200 kV) and cobalt-60 gamma rays, kill malignant cells but cannot be confined solely to the tumour and may damage surrounding healthy tissue. Compounded with this is the progressive energy loss of an X-ray as it travels through the body, producing most ionization at the outset.

On the other hand, protons (or light ions) at a given energy lose most of their energy through ionization near the end of their trajectory (about 16 cm for a 400 MeV/nucleon neon-20 beam, about 26 cm for a 400 MeV/nucleon carbon-12 beam in tissue). Thus a given range-modulated beam can be fired at a tumour located at known depth below the skin surface, dumping most of its energy in the tumour near the end of the trajectory (the Bragg peak) with minimum damage to surrounding healthy tissue. By degrading the beam and spreading the Bragg peak, the beam's energy is spread over a controllable tumour volume.

In 1946, Bob Wilson at Harvard first realized that this technique was a useful weapon against cancer (neutrons were already being used in the late 1930s at Berkeley, but are comparatively difficult to control because of their electrical neutrality and significant scattering in matter). The dose localization and biological advantages of charged particles promise better control of human cancers, but unfortunately precise tumour localization has not been possible until recent years, and so charged particle

therapy has had to wait for its day to come.

Carbon and neon ions offer good dose localization and increased cell-killing power (biological effectiveness) due to their high linear energy transfer (LET). Because of the increased relative biological effectiveness (RBE) in the spread Bragg peak, neon has a favourable peak (tumour) to entrance (normal tissues) ratio and can be dosed so that normal tissue around the tumour receives much less irradiation than the tumour. Silicon ions have high LET all along their path and thus are more suited to treating surface tumours. Easiest to use are protons and helium ions because of their physical properties; however they lack the biological advantages of heavier ions.

Emerging from the Laboratory

Until now most ion beam therapy units have been in particle physics laboratories doing fundamental research (Berkeley, Darmstadt, Fermilab, Uppsala, KEK, Dubna) and therapy has had to take a back seat. This is changing, with projects in the USA, USSR, Japan, Germany, and now EULIMA as a joint European initiative.

Setting the pace is Loma Linda in the US: Fermilab is helping to build a 6-metre diameter proton accelerator for the Loma Linda Medical Center in southern California. After tests, the variable energy synchrotron (70-250 MeV) machine will be moved out west in the summer to become the world's first medical accelerator for deep-seated tumour proton therapy. Loma Linda, with five irradiation points (three fitted with a gantry beam, two with horizontal beam lines) should handle 1000 patients per year.

EULIMA project leader Pierre Mandrillon: a new assault on cancer in Europe.

(Photo CAL, Nice)



At Tsukuba in Japan, a two-room proton treatment centre has been operational since 1983 with beam drawn from the nearby KEK synchrotron, degraded from 500 to 250 MeV by a graphite absorber.

Also in Japan, construction of the Heavy Ion Medical Accelerator (HIMAC) got under way at the National Institute of Radiological Sciences in 1988 with clinical trials scheduled for 1993. The 310 million dollar project was backed by the Japanese government in the context of a 1983 ten-year strategy for cancer.

In Germany the GSI Darmstadt SIS heavy ion synchrotron (see page 24) will accelerate all heavy ions from helium to uranium to energies of at least 1 GeV/nucleon. Situated in the densely populated Rhein-Main area between Frankfurt and Heidelberg, it is an ideal region for a therapy centre. A joint GSI-Strahlenklinik (University of Heidelberg)-German Cancer Research Centre (Heidelberg) proposal for a radiotherapy facility on SIS has been submitted to the German government.

In Switzerland, Hans Blattmann and colleagues at the Villigen Paul Scherrer Institute took the pion technique developed at Los Ala-

The emerging idea for the European Light Ion Medical Accelerator (EULIMA), with a four-sector magnet structure and a single cryostat and vacuum chamber. An external source of the ECR type with an axial injection for stand-alone operation of the machine, as an alternative to a radial injection system from an injector cyclotron, is also shown.

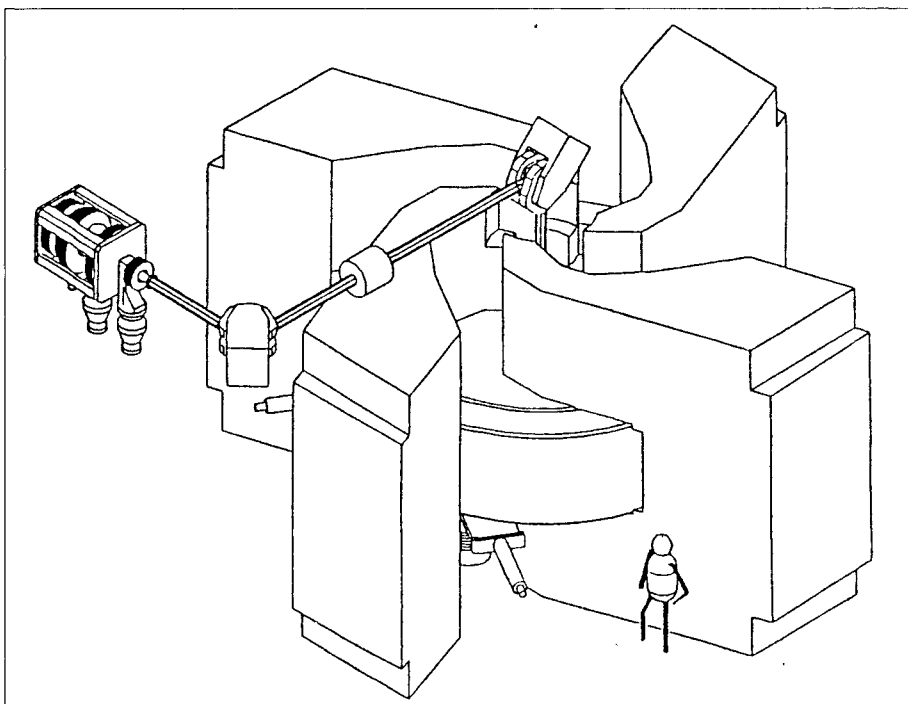

mos and established a spot-scanning irradiation therapy technique in 1981; since then more than 380 deep-seated tumour patients have been treated. New computer programs give pencil beam proton scanning additional flexibility in dose shaping, calculating an optimized scan pattern for a given three-dimensional tumour volume. The pencil beam scanning technique will be tested in a horizontal beam line with a degraded 590 MeV proton beam from the PSI accelerator.

Joe Castro at Berkeley and the University of California Medical Center, San Francisco, are collaborating in clinical trials with helium and heavier charged particles to study the advantages of improved radiation dose localization and enhanced biological effectiveness with the main goal of evaluating the need for high LET charged particles.

Design parameters for a Light Ion Biomedical Accelerator (LIBRA)

adjacent to five hospitals are now being finalized by the Berkeley group for the Merritt Peralta East Bay Medical Center (Oakland, California). Initially the project has a four-year schedule for design, construction and installation; switch-on date not yet fixed.

The EULIMA idea takes shape

EULIMA's key technical concept consists of adding a booster to an existing accelerator with an established heavy particle (neutron or proton) therapy tradition. Preliminary studies have concentrated on a superconducting separated-sector cyclotron, since the desired energy of 400 MeV/nucleon with a beam of oxygen-16 is within reach of a two-stage cyclotron. Project leader Pierre Mandrillon (Nice) presented the basic parameters of this approach and summarized the think-

An early stage of the feasibility study explored the possibilities of operating EULIMA as a stand-alone dedicated facility, or as a booster cyclotron for an existing machine with an active therapy programme, such as those in Nice, Louvain-la-Neuve and Liverpool. In the former case, due to its excellent reliability and high intensity, an ECR source may be used to produce high charge ions matched to the first accelerating orbits in EULIMA by a suitable axial injection system.

Biological and ballistic studies of light ions showed that a 400 MeV/nucleon oxygen-16 beam is a good benchmark. Besides its satisfactory radiobiological performance, a light ion beam offers the possibility of secondary beams such as have been used at Berkeley for precise dose localization, imaging and control of the treatment sessions. In either case, a prerequisite for an efficient therapy programme is an intensity of some 10^9 particles per second in tissue.

EULIMA's design may be based on a synchrotron, as at Berkeley, NIRS (Japan) and Loma Linda, or a cyclotron – as in neutron therapy facilities. Both have advantages and drawbacks. The compact cyclotron was chosen as an option for the feasibility study, and project leader Mandrillon and his team set out to study a separated sector option with a single cylindrical superconducting excitation coil, contributing as much as 50% of the necessary average magnetic field of about 3 teslas.

The EULIMA feasibility study of the past two years has concentrated on several important issues of the cyclotron concept. It fulfils the basic requirements for the reference oxygen beam and leads to a compact, cost-effective and overall technically feasible design. Be-



LOW TEMPERATURE EXPERIMENTS WITHOUT MAKING WAVES

How would you like to conduct your experiments at temperatures to below 4mK with optical and electrical access to your rapidly loaded samples in a system with an integrated superconducting magnet?

To find out more about our range of dilution refrigerators, all available with full warranty and service support from the world leader in cryogenic technology, send for a copy of our brochure "Ultra Low Temperature Systems" from:

Oxford Instruments Limited
Eynsham, Oxford OX8 1TL

OXFORD

A member of The Oxford Instruments Group plc

SCIENTIFIC & TECHNICAL SERVICES (STS)

Consultants in physics and biomedical experimentation: projet design and management, data analysis, statistics, microcomputer applications, EEC liaison

STS celebrates 15 years of independent services to scientific and industrial institutions worldwide, and sends New Year Greetings to friends & colleagues everywhere.

Contact Dr. Ron Fortune:

STS, 72 chemin Ami - Argand, 1290 VERSOIX Geneva, Switzerland
Telephone: (4122) 551311 Fax: 983842 Telex: 427 130 txc ch
8 avenue de Genève, 01220 DIVONNE France. Tél: (33) 50201005

ARBEIT IM AUSLAND

Wünschen Sie ein neues Leben?

Nun ist das Buch herausgekommen, das Ihnen vollständige Auskunft über Arbeitserlaubnis, Lohn-, Arbeits- und Wohnverhältnisse, Visum, Reisekosten, Klima usw. gibt. Sie erhalten auch Adressen von Unternehmen, die europäische Arbeitskräfte in Europa, den USA, Kanada, Westindien, Australien und dem Fernen Osten brauchen. Es gibt Arbeiten wie z. B. Metall, Ölindustrie, Gartenbau, Fahrer, Reiseleiter, Hotel und Restaurant, Au-pair, Luxus-Kreuzfahrten.

Wenn Sie interessiert sind, fragen Sie schriftlich nach unserer Freibroschüre mit weiterer Auskunft über das Buch. Freie Information erhalten Sie gegen voradressierten Briefumschlag mit internationaler Postgebühr. Schreiben Sie an:

- Freibroschüre
- Buch "Arbeit im Ausland"
Preis: 45.- DM

EUROPA BOKFÖRLAG AB
Box 2014 S-135 02 Tyresö Sweden

N.B. Wir vermitteln keine Arbeiten!

Spin symposium

sides providing required beam intensities for standard therapy, the design allows for the use of secondary positron-emitting beams for tumour localization, thus improving therapy procedures considerably. Higher energies of at least 500 MeV/nucleon and heavier particle beams (mass number at least 20), even if recommended by future studies, would be more difficult to obtain this way. Here a synchrotron would be better.

Several design issues have been studied in considerable detail. A separated sector design with a common superconducting coil has a number of advantages over recently built closed yoke superconducting cyclotrons. The main advantage of the EULIMA concept lies in a simpler mechanical design with axial (in iron-free regions), as opposed to radial – through the cryostat – feedthroughs. This, and a fixed frequency regime, indicates that this pilot machine could be designed and constructed without major technical and implementation problems.

The Workshop closed on an optimistic note with reiteration of the physical and biological advantages of light ion therapy. Pierre Chauvel (Nice) and Ross Sealy (Liverpool) concluded that Europe has to catch up with the rest of the world (notably the USA and Japan) in high precision, high LET charged particle radiotherapy. Hopefully EULIMA will fulfil this aim, handling some 1000 patients per year, with many otherwise intractable tumours being cured.

By Seamus Hegarty

Considering the future of accelerating polarized particles during a coffee break. Left to right, Yu. Shatunov (Novosibirsk), J. Buon (Orsay), and K. Steffen (DESY).

The recent 8th International Symposium on High Energy Spin Physics at the University of Minnesota in Minneapolis, Minnesota, opened with a bang when L. Pondrom (Wisconsin), donning a hard hat borrowed from construction workers, ventured that 'spin, the notorious inessential complication of hadronic physics, is finally telling us what real QCD (quantum chromodynamics, the field theory of quarks and gluons) looks like.'

He was referring to an animated discussion on the meaning of the recent spin oriented (polarized) scattering results from the European Muon Collaboration (EMC) at CERN and reported at the Symposium by R. Gamet (Liverpool) and P. Schuler (Yale) which show that the proton spin is not simply a reflection of the spins of its constituent quarks (June 1988 issue, page 9).

Debate among theorists had begun the previous week during a five-day spin theory workshop organized by J. Soffer (Marseille)

and sponsored by the University of Minnesota Theoretical Physics Institute. This lively discussion was a continuous thread through all six days of the subsequent symposium with theoretical opinions ranging from an announcement of the death of QCD by G. Preparata (Milan) to cautious warnings of overinterpreting the data by F. Close (Tennessee). The implications of the EMC results for QCD were illustrated by the different approaches reported by R. Carlitz (Pittsburg) and E. Leader (London).

The EMC controversy was only one example of the vitality of the field. The Minnesota Spin Symposium, with about 300 physicists from around the world, was the largest yet in this biennial series. New experimental results covered a huge range of laboratory energy. At the lowest end of the scale, the static properties of particles, H. Dehmelt (Washington) and Yu. Shatunov (Novosibirsk) reported on different experiments measuring the positron magnetic moment,



For a successful partnership...
For a global system approach...
For a better price/performance ratio...

...THINK CES

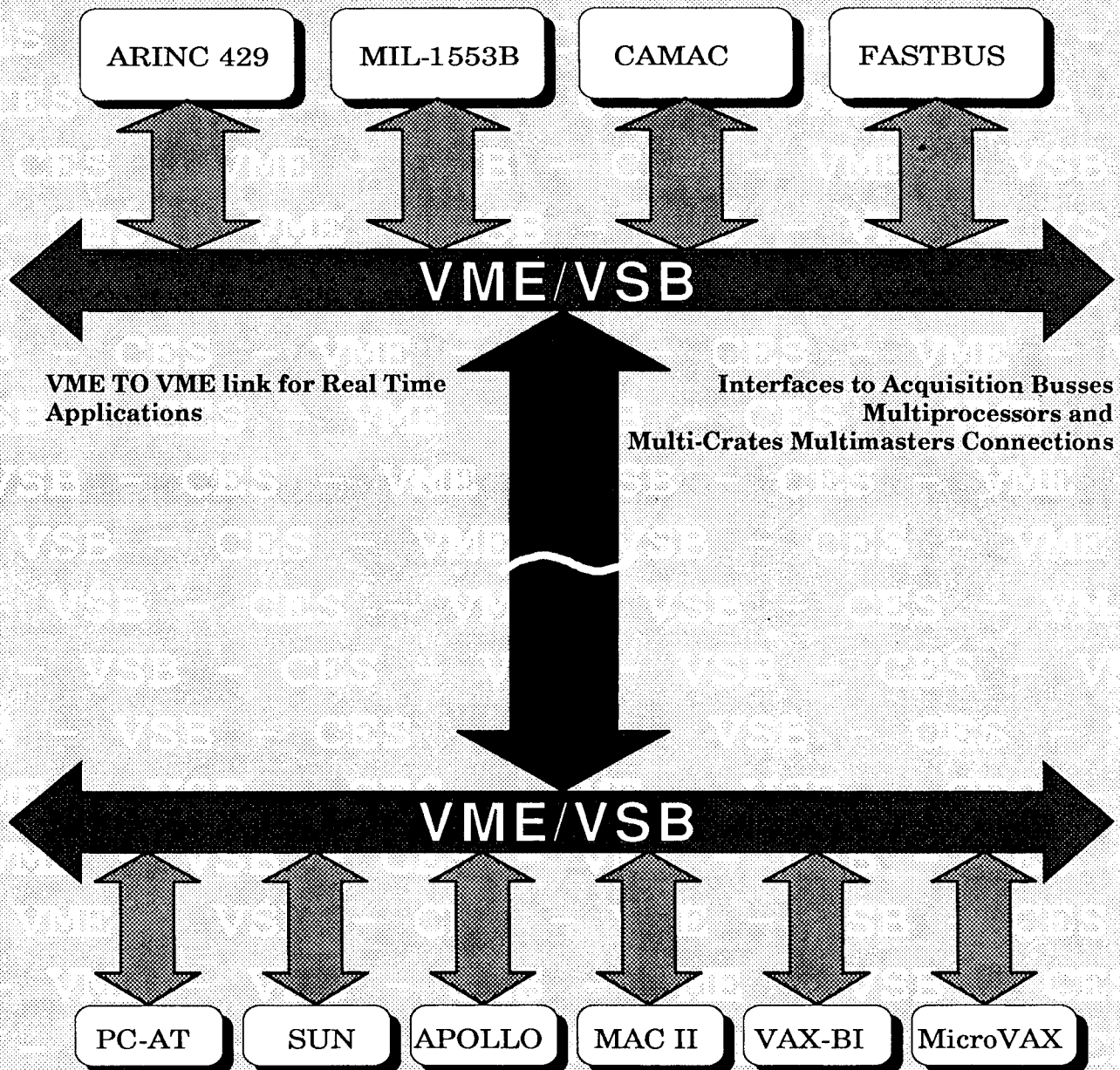

CES Interfaces to Most Popular Host Processors

For these and our other VME and CAMAC modules, contact us for your nearest distributor.
 Headquarters: CES Geneva, Switzerland Tel: (022) 925 745 Fax: (022) 925 748 Tlx: 421 320
 CES.D Germany Tel: (6055) 4023 Fax: (6055) 82 210 Tlx: 418 4914
 CES Creative Electronic Systems SA 70, Route du Pont-Butin Case Postale 107 CH-1213 Petit-Lancy 1 GENEVA SWITZERLAND



CREATIVE ELECTRONIC SYSTEMS

CERN Courier, January/February 1989

O. Chamberlain (Berkeley) and A. Krisch (Michigan) during a Symposium general session.



while V. Hughes (Yale) covered progress towards the new muon magnetic moment experiment at Brookhaven. K. Johns (Minnesota) described an important new result from Fermilab, the measurement of the magnetic moment of the omega minus hyperon (June 1988, page 25).

At the high energy end, the Symposium heard the first results from the new Fermilab 185 GeV polarized proton and antiproton beams from hyperon decay (October 1988, page 25), including the asymmetry of neutral pions produced by protons, and the kinematics of heavy hyperons.

Meanwhile Brookhaven's workhorse Alternating Gradient Synchrotron (AGS) has proved itself to be a reliable source of polarized protons. L. Ahrens described the machine's achievements, with 40% polarized protons of up to 22 GeV, while D. Lowenstein concluded his pan-American status report with an open invitation for proposals to use the Brookhaven polarized beam. M. Nessi (Rice) covered high energy spin transfer measurements in hyperon production; data which

should help solve the mystery of why high energy hyperons come out polarized. S. Heppelmann (Penn State) looked at the asymmetry in pion and proton production by polarized protons. Some large and unexpected effects in proton elastic scattering were described by D. Peaslee (Michigan). This marked spin behaviour occurs moreover in a region where the spin-averaged reaction rate is unremarkable, underlining once again how spin can be a sensitive probe (July/August 1988, page 10).

In Europe, the highest energy polarized proton accelerator is the French Saturne machine. J. Arvieux covered its new MIMAS accumulator-booster ring (May 1988, page 5). The Japanese KEK machine's new polarized proton capabilities were pointed out by A. Masiake (Kyoto), and S. Hiramatsu (KEK) reported that beam has now reached 5 GeV with 25% polarization.

An intriguing interim result from the Institut Laue-Langevin reactor at Grenoble came from M. Pendlebury (Sussex), with a large (10^{-25} e-cm) neutron electric dipole moment, agreeing with an earlier

Leningrad measurement.

Other new results showed no parity violation in p-d scattering at the 10^{-7} level from a 45 MeV PSI experiment reported by J. Lange (ETH, Zurich) and an 800 MeV LAMPF experiment reported by R. Mischke (LAMPF). These results at lower energy are more precise than the existing 6 GeV parity violation found at Argonne. Something very interesting could be happening between 1 and 6 GeV.

Lively intermediate energy sessions included many new measurements of spin observables to challenge theory. As reiterated by R. Silbar (LAMPF), the regularities observed may provide a hint. Big news from these sessions was the resurrection of dibaryons. Experiments at Saturne, reported by de Lesquen (Saclay), and LAMPF, Los Alamos, reported by M. Gazzaly (Minnesota), have found narrow structures in polarized proton scattering. However the interpretation of these new results is still controversial.

As usual, this Symposium highlighted the close links between experimental high energy physics and accelerator technology, as exemplified by the recent convergence of polarized ion source and polarized target technologies. Important new work was reported in both the traditional atomic beam and the optical polarization sectors applied to source and target development.

E. Steffens (MPI, Heidelberg) described a project to improve polarized atomic beams using a storage cell for use as an internal target. Y. Mori reported on the laser polarized ion source in routine use at KEK, while news of further developments of this technique came from A. Zelensky (INR, Moscow) and C. Levy (TRIUMF). D. Bowman (LAMPF) told how a laser polarized

Exchanging spin views during a ride down the Mississippi during a break in the Symposium. Left to right, M. Moreno (Mexico), P. Taxil (CERN), C. Joseph (Lausanne), and A. Gersten (Ben-Gurion).

gas cell was used to produce polarized neutrons in an experiment to observe parity violations in neutron scattering. A new laser polarized deuteron gas jet target developed by an Argonne/Novosibirsk collaboration has been used in electron scattering at the Soviet VEPP-2M ring at Novosibirsk (D. Torpokov).

The significant progress in polarized gas jet targets was summarized in a two-day workshop at Minnesota preceding the Symposium and organized by W. Haeberli (Wisconsin) and E. Steffens (MPI, Heidelberg).

Taking polarized proton beams to energies above those of the Brookhaven AGS requires finessing so many depolarizing resonances that much effort has gone into investigating the 'Siberian Snake' magnet configuration first proposed by Derbenev and Kondratenko. Various designs and applications were presented by E. Courant (Brookhaven), S. Y. Lee (Brookhaven), and K. Steffen (DESY). A. Krisch (Michigan) described the first experimental snake test soon to be performed at the newly commissioned Indiana Cyclotron Cooler Ring (July/August 1988, page 13).

The use of Siberian Snakes at future accelerators was the subject of another workshop at Minnesota preceding the Symposium and organized by T. Roser (Michigan). Roser presented a new idea of using a partially excited snake to cancel weak low energy resonances; this could provide polarized proton injection for proposed new accelerators. On a different tack, R. Rossmanith (CEBAF) proposed using the Stern-Gerlach effect to polarize antiprotons in CERN's LEAR low energy ring.

The importance of polarization in high energy electron accelerators



was stressed by D. Barber (DESY). K. Moffeit (SLAC) reported that most of the components needed for electron polarization at Stanford's new SLC linac now exist, and polarization should follow soon after the machine begins physics. K. Steffen (DESY) described the spin rotator installed for tests at the HERA electron-proton collider being built at the German DESY Laboratory. For the LEP electron-positron collider nearing completion at CERN, ongoing polarization studies were reported by J. Koutchouk. The considerable progress in calculating depolarization effects was described by S. Mane (Fermilab). New polarized electron-positron accelerators such as SLC and LEP will have a great potential to test standard physics ideas, while HERA and CEBAF will use polarization to probe particle structure.

Novosibirsk, with several machines in operation or being built, is very active in electron-positron polarization studies (Yu. Shatunov, S. Popov, and A. Zholents). L. Soloviev, the director of the Serpukhov Laboratory, covered polarization facilities in the Soviet Union, including active spin physics at Novosibirsk, at the 70 GeV Serpukhov proton accelerator, and at the 9 GeV Dubna polarized deuteron accelerator. The future looks especially exciting at the 400 GeV - 3 TeV UNK machine now under con-

struction at Serpukhov, where the programme includes polarization experiments by the international NEPTUN collaboration. R. Raymond (Michigan) described the ultra cold Michigan-MIT polarized gas jet which may be used as an internal target for UNK's first experiment, a study of proton elastic scattering asymmetry at large transverse momenta.

Symposium participants were reminded that basic research can lead to practical applications even in the quantum mechanical world of spin. R. Damadian (FONAR), one of the originators of magnetic resonance imaging (MRI), demonstrated in his talk on the history and prospects of MRI that the medical aspects of spin physics have only begun. Great progress in medical diagnosis can be expected when the structure of the nuclear spin signal is married to advanced imaging techniques.

Summarizing the Symposium, G. Bunce (Brookhaven) stressed the importance for spin physics of close collaboration between physics and technology, and pointed out the rapid advances achieved between successive biennial Spin Symposia. This bodes well for the 9th International Symposium on High Energy Spin Physics to be held in September 1990 in Bonn.

Linear colliders

At the recent Linear Collider Workshop at the Stanford Linear Accelerator Center (SLAC) – left to right, Pisin Chen of SLAC, Kaoru Yokoya of KEK (Japan), Norman Kroll of UC San Diego and Ron Ruth of SLAC. Below – Karl Brown of SLAC with Joel Le Duff and Michel Davier of Orsay.

(Photo SLAC)

From November 28 to December 9, the Stanford Linear Accelerator Center hosted an International Workshop on Next Generation Linear Colliders. The attendance, including delegations from CERN, Frascati (Italy), KEK (Japan), Livermore (US), Novosibirsk (USSR), Orsay (France) and SLAC itself reflected the international interest in this new approach to higher energies.

The world's experts on linear colliders had come to learn from recent experience with the Stanford Linear Collider (SLC), to discuss their research and development programmes, and to compare notes on the design of possible new machines. SLAC Director Burton Richter opened the two-week conclave with a recommendation that the various interested groups of accelerator physicists pool their talents and collaborate on the R & D necessary for the next linear collider.

Subsequent plenary speakers outlined the current state of knowledge in such areas as design parameters, damping rings and sources, accelerator structures, beam dynamics, instrumentation and control, radiofrequency power sources, and final focus design.

In his 'Struggle for High Luminosity' talk, Robert Palmer of Brookhaven and SLAC explained the thinking behind the TeV Linear Collider (TLC). This 7/8 kilometre, 1 TeV collider intended for the SLAC site must produce the $10^{33-34} \text{ cm}^{-2} \text{ s}^{-1}$ luminosities required for electron-positron physics in this energy range.

Then Wolfgang Schnell outlined the choices made by the CERN team designing its CLIC linear collider, a 2 TeV machine to give 10^{33} luminosity and a possible increase in a multibunch mode. Accelerating

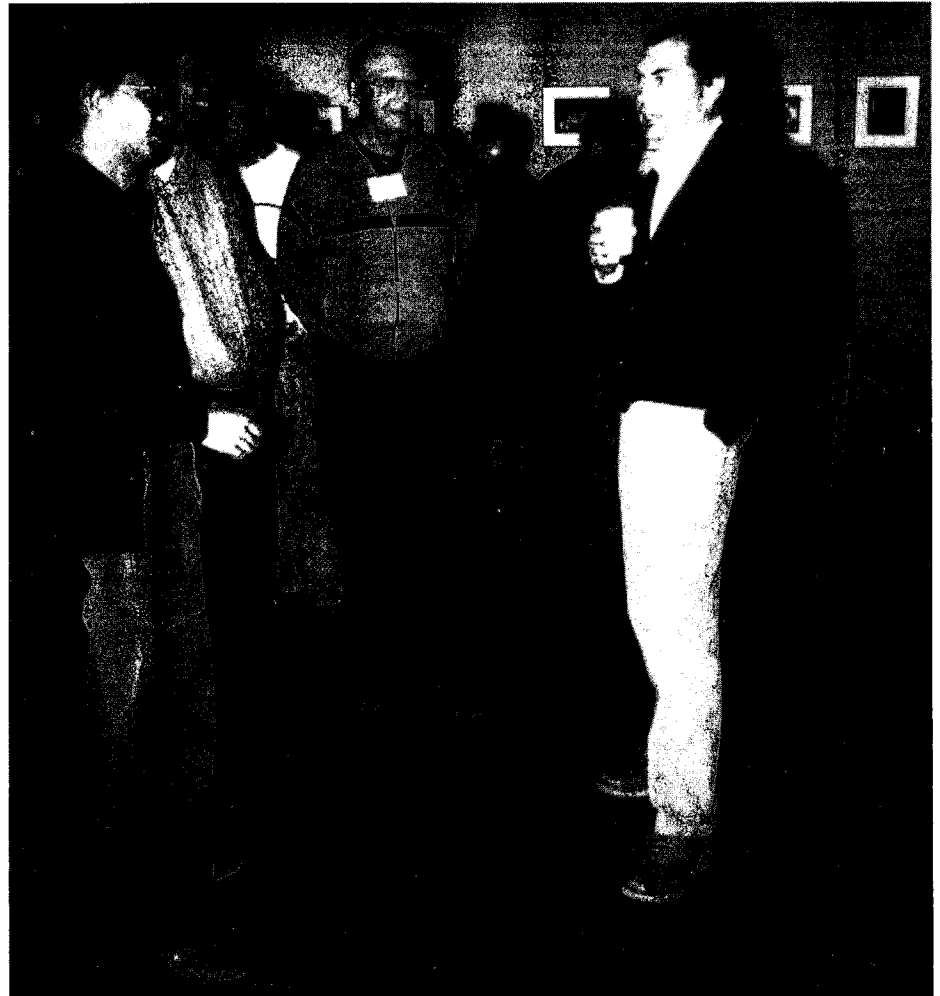

PERMALI COMPOSITES

37, rue de la Liberté - 38602 FONTAINE CEDEX - B. P. 75
 ☎ 76 26 08 45 - TÉLÉCOPIE 76 27 00 72 - TÉLEX 320855 PERMALI
 Siège social: 8, rue A.-Fruchard - 54320 MAXEVILLE

*Les moyens d'élaboration
 et de transformation
 de matériaux haut de gamme
 ont permis à notre société
 d'intervenir avec*

PERMAGLAS

*sur l'accélérateur
 de particules «HERA» de
 Hambourg*

Consultez-nous!

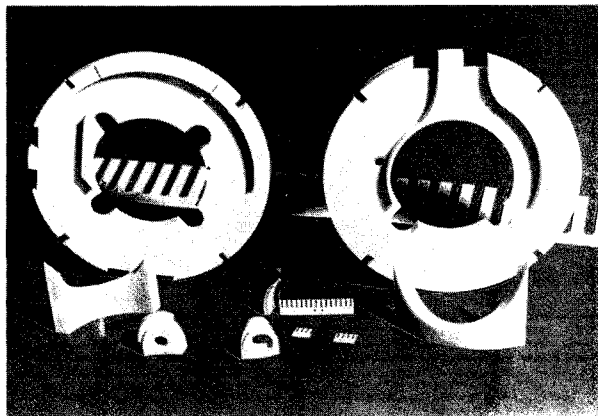
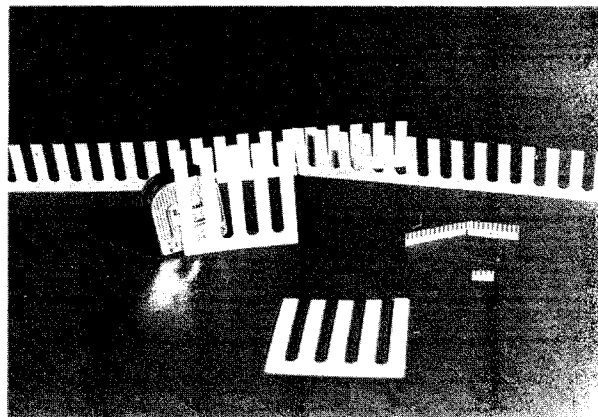

41, rue de Villiers, 92200 Neuilly-sur-Seine, Tél. (1) 40.88.20.00

AUBERT & DUVAL

aciérie des ancizes

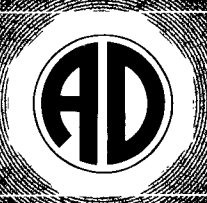

aciers spéciaux
 et
 super alliages
 pour techniques avancées



HOUVENAGHEL

LA FORCE EN ACTION

—
 Electrotechnique
 Electronique
 Groupes electrogenes
 Climatisation
 Tôlerie
 —

Fournisseur du CERN
 en
 redresseurs de puissance
 pour
 éléments magnétiques
 du LEP

Siège Social:
 L'ÉPINAY - 76400 FECAMP (FRANCE)
 Tél: 35.28.11.23 Télax: 190683 F
 Télécopieur: 35.28.69.20

sections would be powered by a superconducting drive linac running in parallel.

Alexander Skrinsky described the Soviet VLEPP project, including the 1 TeV electron-positron linear collider scheduled for construction at Serpukhov in the mid-1990s. Mazakasu Yoshioka discussed parameters for the Japan Linear Collider (JLC) and summarized the extensive development underway at KEK.

Workshop participants then broke up into smaller groups for a week of intensive discussions on areas of special interest, reconvening for the final two days of summary talks from the various working groups.

One of the most significant results to emerge came from the 26-strong group considering final focus designs. In discussions with Valery Telnov of Novosibirsk, Pisin Chen of SLAC recognized that coherent electron-positron pair production – by beamstrahlung photons interacting with the magnetic field of the other bunch – may generate intolerable backgrounds in the surrounding detector. For TLC beams with 10^{10} particles per bunch, the coherent production dominates the incoherent by about a factor of 200. What's more, background particles are generated with the *same* charge as the opposing beam, so that they can receive a substantial transverse kick.

The coherent pair production rate can fortunately be controlled by reducing the magnetic fields of the beams. This can be accomplished by reducing the charge density per bunch, which in turn requires increasing the number of bunch crossings per second in order not to lose luminosity, or by increasing the aspect ratio of the beams. Allowing a larger exhaust

port for the pairs (through the final focus quadrupoles) may require use of a larger crossing angle than previously anticipated – 60 milliradians instead of 3 – which may require the so-called 'crab crossing' design to retain luminosity. Whatever the eventual outcome, all sets of parameters advocated in the various linear collider designs will have to be reviewed and revised to take account of this pair-production phenomenon.

Other groups had significant, if less startling, results to report. Those physicists working on damping rings agreed that wiggler magnets were an attractive means of producing low-emittance beams rapidly – permitting higher repetition rates. The favoured accelerator structure is the disk-loaded waveguide with an iris radius of 20 percent of the r.f. wavelength – 2-6 cm in the designs being considered. For multibunch operation (many bunches per r.f. fill, as in the SLAC design and as an add-on for CLIC) slotted structures are needed to damp the transverse r.f. modes that would otherwise cause beam breakup. BNS damping (December 1988, page 13) was a favourite method advocated to control growth of transverse tails on the bunches.

One of the key problems to be solved is in the r.f. power sources needed to drive the linear colliders. No current solutions simultaneously meet all the requirements of peak power, repetition rate, efficiency and cost, although the first three have been demonstrated separately.

Although the present sets of design parameters appear diverse, there are common problems that will benefit from collaboration on R & D, as underlined in the working groups. For example, ongoing col-

laboration between KEK and SLAC has benefited r.f. power source and accelerator structure development, as well as final focus design.

One possible international collaboration is the Final Focus Test Beam being considered for SLAC. This beamline would take the beam straight ahead from the end of the linac and use TeV linear collider optics scaled down to 50 GeV to produce intense, submicron beam spots. Optics, components, instrumentation and precision alignment techniques could be tested.

In summary, workshop organizer Ewan Paterson of SLAC observed that the problem of beamstrahlung pair production had already ushered in a 'new wave' of linear collider fashions. Multibunch operation, slotted accelerator structures, large crossing angles, crab crossing, wigglers in damping rings, and BNS damping were all 'in' now. Collimators in the final focus were decidedly out, and the need for more r.f. power has not changed. 'Complementary linear collider designs are very important', Paterson added, 'because we learn from everybody's different problems.'

From Michael Riordan

**IEC-Bus (IEEE 488)
RS 232 compatible boards**

- bidirectional
- 12 to 16 bits
- direct programming in absolute values for voltage and current
- potential free

ask for the catalog 14

HEINZINGER
electronic GmbH

**Bus - controled
Power supplies**

Anton Jakob-Str.4
D-8200 Rosenheim
West Germany
Tel. 08031/44040
Fax. 08031/440444
Tlx. 525777

**METALS & MATERIALS
FOR RESEARCH & INDUSTRY**

CATALOGUE 1989

NEW EDITION

FREE

SMALL QUANTITIES FAST
TELEPHONE (0223) 420631 FAX (0223) 420639

► RESEARCH QUANTITIES AT YOUR FINGERTIPS ► OVER 450 PAGES
► 50,000 STANDARD PACKS ► OVER 3500 ITEMS IN STOCK
POLYMERS · CERAMICS · METALS · ALLOYS · COMPOSITES · COMPOUNDS

EXPRESS SERVICE

Small quantities FAST: In your hands 48 hrs UK/Europe, 72 hrs Worldwide
GOODFELLOW, The Cambridge Science Park, Cambridge CB4 4DJ, England
Tel (0223) 420631, Fax (0223) 420639

Goodfellow

**STABILISED
POWER SUPPLIES**

For linear and circular particle accelerators with resistive or cryogenic magnets.
For heavy and light ion sources.
For triode, tetrode, klystron and H.F. power amplifier tubes.

Installations :
Europe, USA, Japan
100 W to 600 KW
to 1.10⁻⁵

JEMA S.A.
rue Doct. De Meersman, 37
B1070 BRUXELLES
Tel. (02) 520 45 76
Fax (02) 522 19 78
Telex : 22674

Around the Laboratories

DESY's new proton linac supplies particles at 50 MeV.

DESY Hamburger protons

As part of the preparations for the HERA electron-proton collider, proton beam tests have started at the German DESY Laboratory in Hamburg.

DESY stands for Deutsches Elektronen Synchrotron, and since its inception in 1959, the Laboratory has used electron and positron beams. However the arrival of the HERA project called for a proton source.

First 50 MeV protons (or more accurately the negative hydrogen ions usually used these days as the first stage of proton acceleration) were provided by the new Linac III on 18 November. This new linear accelerator, designed to supply 10 mA of 50 MeV ions, was built in close collaboration with Laboratories with extensive proton beam experience. The ion source followed a Fermilab design, while the

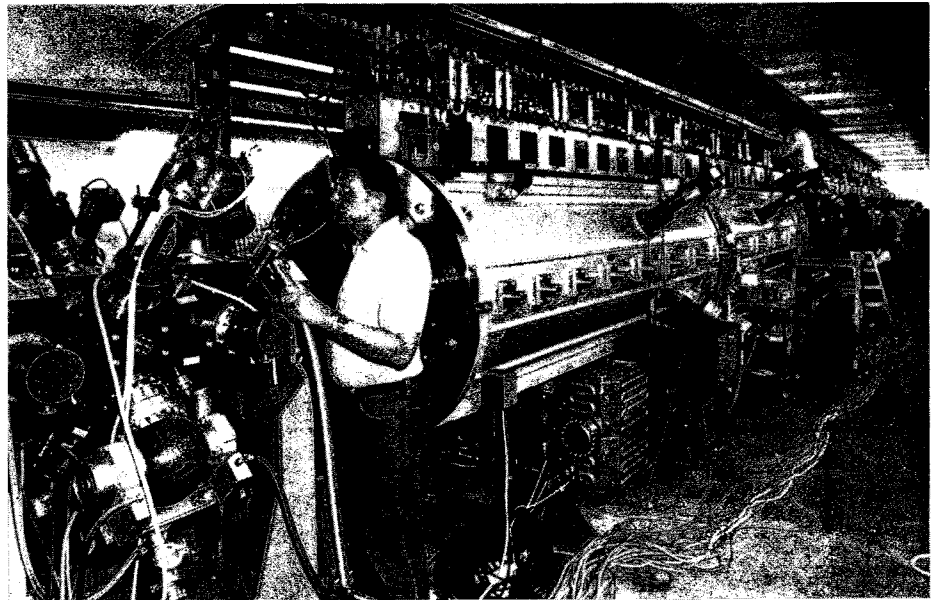

Alvarez accelerating tanks were based on CERN Linac II drawings. The tanks were copper plated at GSI Darmstadt.

Initial acceleration from 18 to 750 keV is provided by a 1.2 metre radiofrequency quadrupole (June 1987, page 1). Design and computations for this RFQ, built at

Frankfurt, were carried out by S.H. Wang of Beijing as part of China's contribution to the linac in particular and HERA in general.

Another international contribution, this time from the Canadian TRIUMF Laboratory, is the 80 metre beam transport system to take the ions from the linac to the new DESY III synchrotron. At injection into DESY III, the ions are stripped of their electrons by an aluminium oxide foil and continue their way as protons. A system of four fast kicker magnets (built at the University of Hamburg) sends the beam through the stripping foil while the synchrotron accumulates more ions, a procedure repeated every four seconds.

DESY III was built in 1987 using the iron yokes of the original DESY I bending magnets. These 4.6 metre units now bend and focus the beam, and have been comple-

Hamburger synchrotrons – DESY II on the inside handles electrons and positrons for HERA while the outer DESY III ring will take protons from 50 MeV to 7.5 GeV.

(Photo Nick Wall)

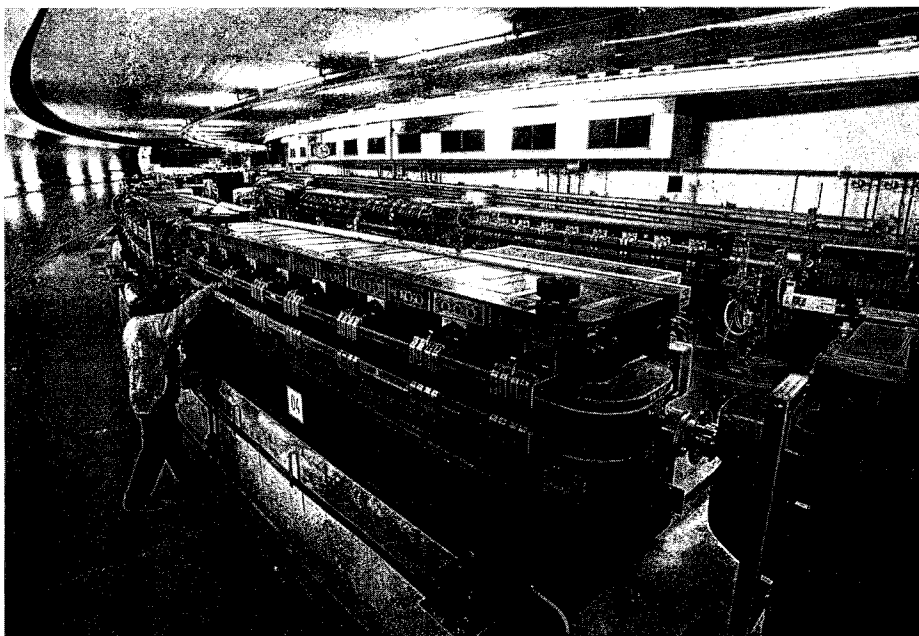

The HERA electron-proton collider now being built at the German DESY Laboratory in Hamburg will handle polarized (spin-oriented) electron beams. Here are some of the movable supports for the complicated spin rotator magnets, which will have to be moved up and down for different beam optics.



mented by additional quadrupoles and multipoles. The 317 metre circumference DESY III, designed to take protons up to about 7.5 GeV, surrounds the new DESY II machine handling HERA electrons and positrons. DESY III's protons will be injected into the PETRA ring to be boosted to 40 GeV before being taken to HERA and there on to about 1000 GeV.

Earlier (October 1988, page 20), the 6.3 km HERA ring handled its first electron beams. Most tests were at 7 GeV, with a few 10^{10} particles per bunch stored, however later 10 GeV single bunches were ejected from the intermediate PETRA ring using a fast kicker

magnet, transferred to the new ring and accumulated there either in a single or nine equally spaced 'buckets'.

The electrons could then be taken up to 14 GeV without loss, the energy being limited at the time by the water cooling system. Thus although the full complement of 82 radiofrequency accelerating cavities had been installed, only 14 could be powered for the tests.

Next task is to complete the magnet water cooling, the lead synchrotron radiation shielding, and the radiofrequency system. With the inclusion of superconducting accelerating sections, an energy of 33 GeV is on the cards.

Except for some minor work, all HERA civil engineering has been completed, and the bill is within one per cent of the original target figure, updated for inflation.

FERMILAB New neutrino directions

After two successful fixed target Tevatron runs in 1985 and 1987, the present neutrino programme at Fermilab has drawn to a close with the experiments agreeing with each other and with the faithful Standard Model.

The long-standing discrepancy in the neutrino-nucleon reaction rate between studies at CERN and Fermilab has been resolved. Muon pairs, with each particle carrying the same electric charge, now appear at the prescribed rate, and the new 1987 data should go on to provide important new information on the quark content (structure functions) of nucleons. Thus it was an appropriate time to review the data and examine possibilities for the future in a 'New Directions in Neutrino Physics at Fermilab' meeting last fall.

The meeting got off to a good start when Fermilab Director Leon Lederman suggested throwing theorists (and their advice) out the window. Before complying, subsequent speakers covered the results accumulated so far. In particular J. Morfin (Fermilab) looked for agreement and disagreement among the various measurements of structure functions. A Snowmass study group has been set up to coordinate structure function data.

Paul Langacker (Pennsylvania) looked at the theoretical basis for

VETRESIT.®
The complete answer.



COMPOSITES

MICAFIL

MICAFIL composites. Why not benefit from our experience ?

LOW DENSITY

For strong light weight components

FLEXIBILITY

Adaptable material properties for specific applications

HIGH MECHANICAL STRENGTH

Appropriate fibre alignments ensure maximum strength along main axes, even at temperatures from 4 K...155 °C

GOOD ELECTRICAL PROPERTIES

Low dielectric losses and high electric strength

RESISTANT TO HEAT AND MOISTURE

Up to class F (155 °C) and class H (180 °C)

GOOD RESISTANCE TO CHEMICAL ATTACK

Solvents, mineral oils, acids and bases

MACHINED PARTS TO CUSTOMERS REQUIREMENTS

Produced on NC-machines

*Machined parts from Vetresit in the BEBC
(Big European Bubble Chamber) in Cern, Geneva.
Vetresit under thermal cycles from 4 °k to 300 °k.
20 years experience with Vetresit composites
in Nuclear Reserarch.*

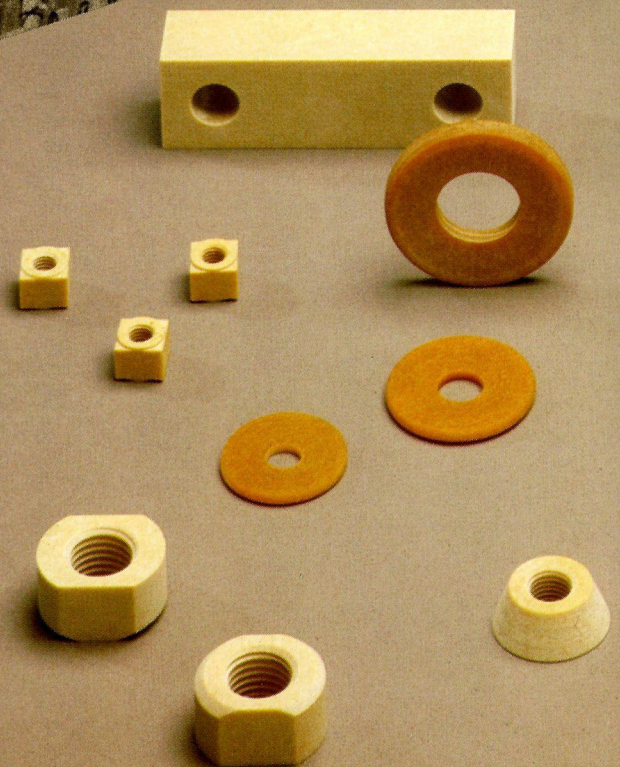

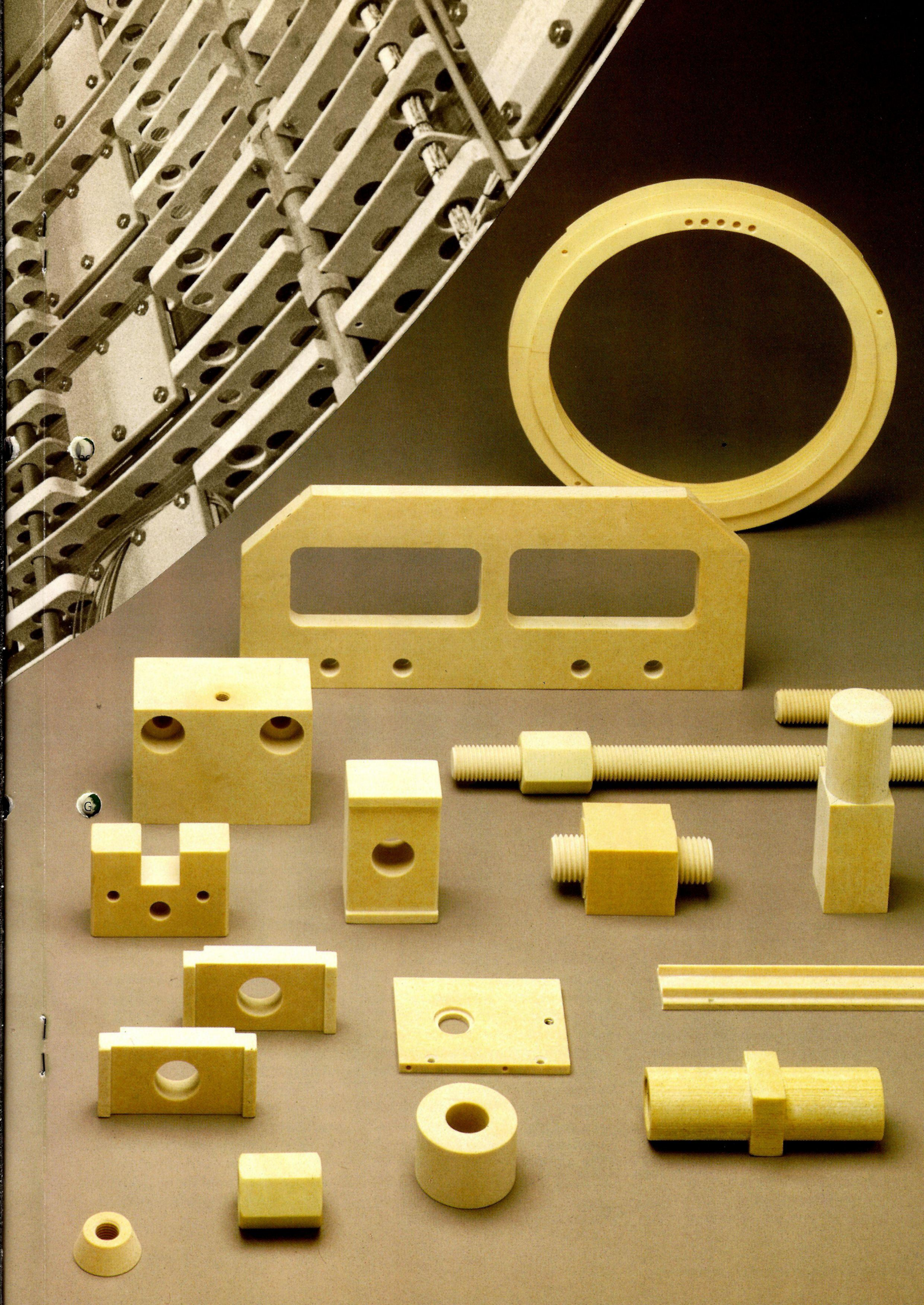

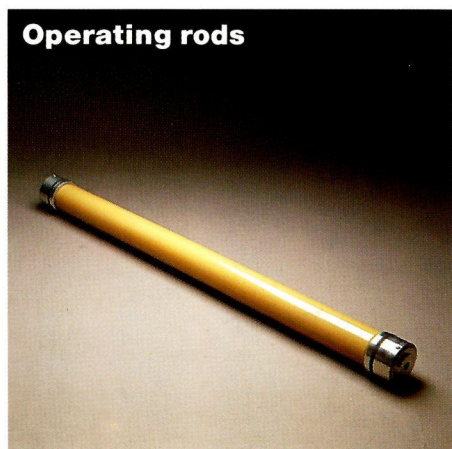
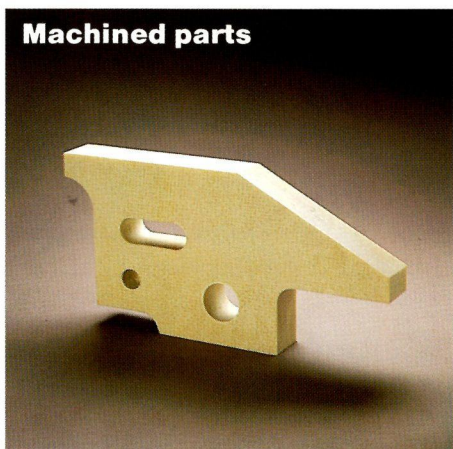
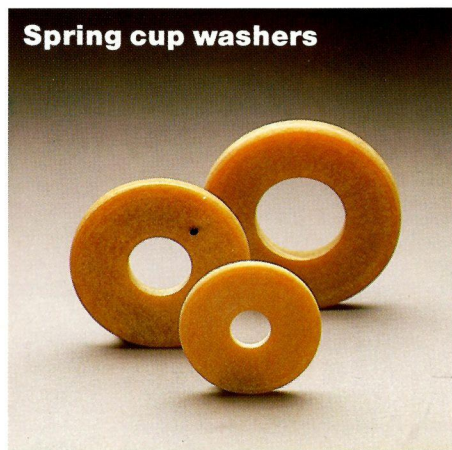
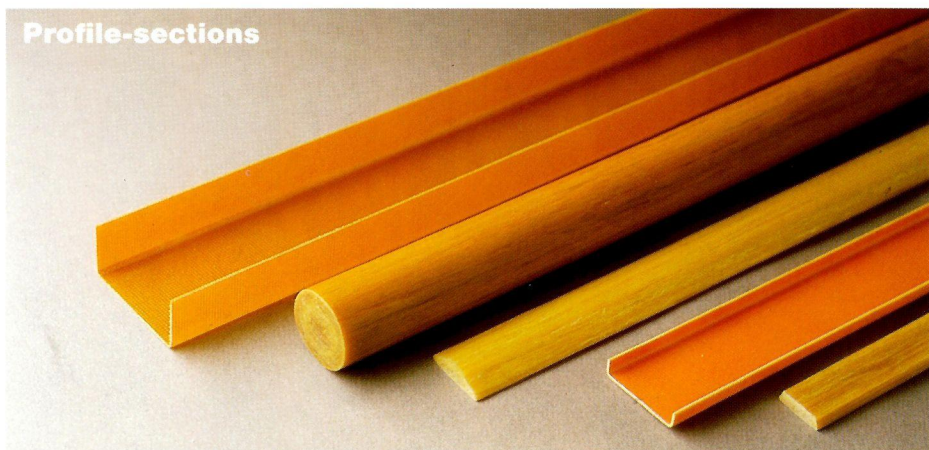
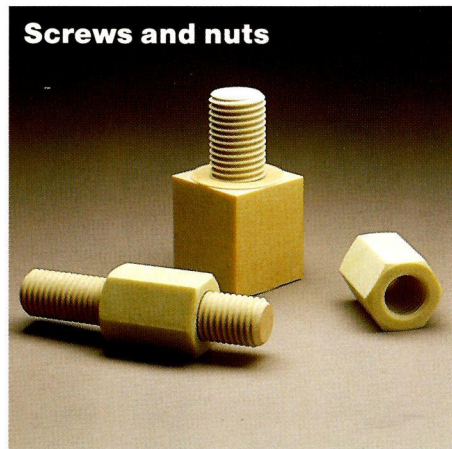
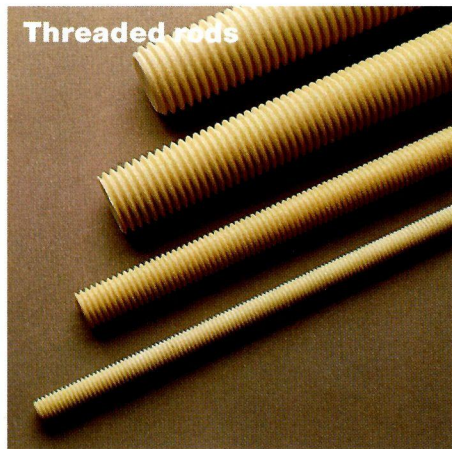
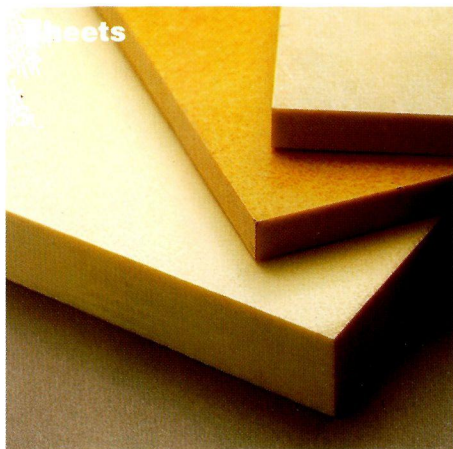

Micafil Ltd. Zurich Switzerland	Badenerstrasse 780 P.O. Box CH-8048 Zurich	Telex 822163 mic ch Telefax 01/435 62 62 Phone 01/435 61 11
Micafil, Inc. USA	100 Holiday Drive Englewood, OH 45322	Phone (513) 836 1110 FAX (513) 836 1119 Tx 629-41349

neutrino oscillations (instead of immutable neutrino types), pointing out different possibilities.

The second day examined new options. For an old new idea – a muon storage ring as a neutrino source – W. Lee (Columbia) described physics possibilities and D. Neuffer (Los Alamos) presented design parameters, mentioning that the Fermilab antiproton source/debuncher is already nearly ideal. Other speakers examined further fixed target neutrino physics approaches for Fermilab and for the new UNK 3 TeV ring being built at Serpukhov near Moscow. Returning to results, T. Kitagaki (Tohoku) had new results on the 'EMC effect' (the dependence of structure functions on the surrounding nuclear environment) from the heavy-liquid bubble chamber. The effect is seen in events with nuclear breakup, but not in coherent recoils.

The final day began with some ideas for long-baseline oscillation measurements. J. Bjorken (Fermilab) described an inexpensive two-distance experiment using the earth as a target and fleets of detector trucks placed hundreds of miles from each other and from the neutrino source. 'Any improvement of the limits by a factor of ten, be it in mixing angle or mass, is worth the effort,' he claimed. M. Koshihara (Tohoku) looked at the possibilities of a megaton water target.

In a final session devoted to plans and results at other Laboratories, A. Capone (CERN) presented a status report from the CHARM II collaboration at CERN, which has the important goal of making precision measurements in the scattering of neutrinos off electrons. Brookhaven too has a long and continuing neutrino tradition, and S. Aronson sketched a future scenario.



Summarizing, W. Marciano stressed the importance of precision measurements of electroweak mixing parameters and of testing oscillation limits in as many ways as possible.

Advanced computing from Italy

A new Advanced Computer Project (ACP) computer system was recently commissioned at Fermilab. Purchased by the Italian National Institute for Nuclear Research (INFN) through the University of Milan, which collaborates in the heavy quark photoproduction experiment E-687, the new 25-node system will be operated by Fermilab's Computing Department for the INFN. First target is analysis of E-687 data from the latest fixed target run.

This is the third production ACP

The new Italian Advanced Computer Project system in Fermilab's Computing Centre with some of its owner/users and support staff. Left to right, Gian Alimonti, Dario Menasce, Margheritta Vittone (Milan), Paul LeBrun, Chip Kaliher, Arnaldo Valderrama, Peter Cooper and Jim Meadows (Fermilab Computing Department/Research Division).

system on-line at Fermilab. These three systems, totaling 142 nodes, are used to analyse recent data from fixed target studies and from the CDF experiment running at the Tevatron collider.

E-687's latest batch of 2000 data tapes will require the equivalent of 24 ACP nodes working full time for one year for primary data analysis. Together, recent data from all the fixed target experiments plus that from the current collider run amounts to about 40,000 tapes, requiring 400 node-years. The largest single client, the charmed hadroproduction experiment E-769, has 10,000 tapes and requires 170 node-years to complete its first pass. All experiments plan to use ACP systems for at least their primary data analysis, and some plan also to run large detector simulation programs this way.

The ACP systems are based on a group of microprocessors running in parallel. Each node is a

HIGH POWER HIGH VOLTAGE

When you choose Brandenburg International, you choose a specialist manufacturer calling upon the most advanced technology.

Our high power supplies have maximum output powers between 3KW and 60KW, giving output voltages to 420KV (bi-polar), and 350KV to ground.

You choose optimum performance.

All our supplies incorporate an 8032 Intel Microcontroller giving them a unique programmable versatility via a serial interface.

You choose optimum flexibility.

Our power supplies have many different applications, including medical and industrial X-ray, nuclear and scientific research, ion beam implantation, electron beam welding, lasers, high voltage testing and charging capacitors.

For further details on how we can solve your power problems contact Stuart Morgan.

Brandenburg International. We have the power.



brandenburg

High Street, Wollaston, Stourbridge,
West Midlands DY8 4PG, England.

Telephone: 0384 393737 Telex: 337482

Fax: 0384 440777.

nouveau:
tubes en acier inoxydable
soudé et sans soudure

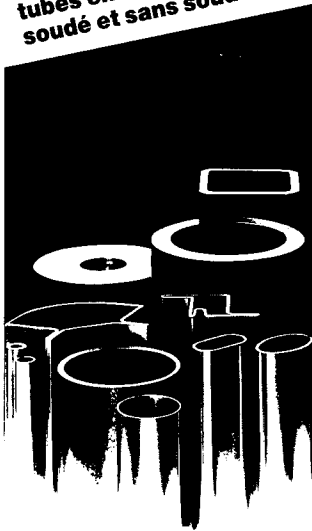

Kindlmann ag

Toggenburgerstrasse 120, Postfach, 9500 Wil SG
Telefon 073-25 11 11, Telefax 073-23 43 43, Telex 883 200

nouveau:
tubes en acier inoxydable «ARFA»
livrable du stock

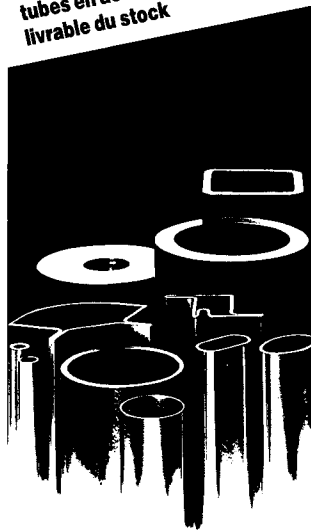

Kindlmann ag

Toggenburgerstrasse 120, Postfach, 9500 Wil SG
Telefon 073-25 11 11, Telefax 073-23 43 43, Telex 883 200

The variation with collision energy of the exponential slope parameter (b) in the elastic scattering of protons off protons (circles) and antiprotons off protons (x), showing how the forward diffraction peak shrinks with increasing energy.

single board computer with either 2 or 6 megabytes of memory. The 25 node INFN system, for example, has more than half the computing power of the present Fermilab VAX cluster. When a computation can be broken into many small, similar tasks, as in the analysis of individual events, the ACP is a very cost effective solution. Other problems are less well suited for ACP handling – the technique is not necessarily a replacement for general purpose computers.

Six ACP central computing systems with a total of 400 nodes should soon be available, boosting Fermilab's central computing to a total of 300 VEQ (VAX 11/780 EQuivalents) via ACP systems, with 55 VEQ on VAX systems, and 120 VEQ on the Amdahl 5890/600E, while the three Control Data Cyber 175s will be decommissioned.

Despite a five-fold increase in the past few years, nearly all available computing power is earmarked. However new experiments now being analysed could not have been contemplated without the knowledge that such large computing resources would be available. These resources have become a tool for doing physics which couldn't be done before.

CERN Elastic scattering

Elastic scattering, when two colliding particles apparently 'bounce' off each other like billiard balls, may not be the most exciting way of studying physics, but can nevertheless provide deep and very satisfying insights into the basic principles governing particle behaviour.

Particularly incisive results come

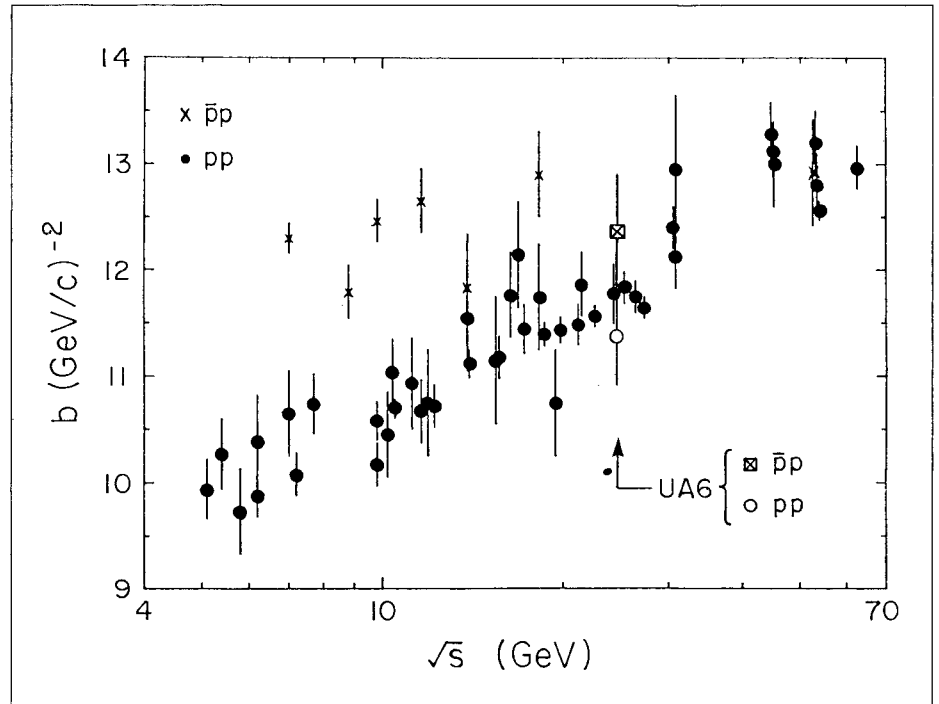

from a comparison of the elastic scattering of protons on protons with that of protons on their anti-matter counterparts, antiprotons.

CERN's Intersecting (proton) Storage Rings (ISR), closed in 1984, handled antiprotons from 1981, and were able to compare proton-proton and proton-antiproton behaviour over collision energies from 30 to 62 GeV.

New elastic scattering results, for the proton-antiproton case only, reported last year from the UA4 experiment at CERN's proton-antiproton collider (January/February 1988 issue, page 32), hinted that something unexpected happens at collision energies around 546 GeV. These effects could go on to become even more spectacular at the higher collision energies envisaged at future big proton colliders.

In particular, the UA4 results do not necessarily underline the popular claim that the difference between proton and antiproton behaviour decreases at higher energies, the two eventually merging together.

Eschewing these high energy horizons, the UA6 experiment (CERN/Lausanne/Michigan/Rocke-

feller collaboration) uses CERN's proton-antiproton collider in a different way. Instead of the stored proton and antiproton beams hitting each other, one beam hits a jet of hydrogen gas squirted across its path, making for a high collision rate at a collision energy of 24.3 GeV (April 1985 issue, page 102). Proton-proton collisions are also studied.

The elastic scattering part of the experiment relies on an array of solid-state detectors 85 cm from the beam-jet intersection to pick up the protons recoiling out of the gas jet (a technique pioneered at the Joint Institute for Nuclear Research at Dubna near Moscow) instead of the more conventional 'Roman Pot' method with detectors placed as near the beam as possible.

Key parameters are b , the exponential falloff of the scattering spectrum away from its central maximum, and ρ , the ratio of the real and imaginary parts of the underlying scattering amplitude.

The UA6 results tie in with the conventional view of protons and antiprotons, and do not mirror the UA4 findings from much higher energies. The accurate measurements are particularly useful.

**UNIVERSITY OF VIRGINIA
EXPERIMENTAL HIGH ENERGY PHYSICS**

ASSISTANT PROFESSORSHIPS

The Department of Physics at the University of Virginia is seeking qualified applicants for tenure track assistant professor positions for an experimental high energy physics group now in the process of formation.

This group has a major involvement at Fermilab in heavy flavor physics in experiment E705 and in beauty physics in experiment E771.

They also have a strong interest in future beauty physics options at both Fermilab and/or the SSC. Candidates should have compatible research interests.

Interested parties should submit a resume and the names of at least three references to:

**Professor Michael Fowler, Chairman
Department of Physics
J.W. Beams Laboratory of Physics
University of Virginia
McCormick Road
Charlottesville, Virginia 22901**

Phone: 804/924-3781

The University of Virginia is an equal opportunity employer.

T H E V E N E T C L E R J O U N I E

TRANSITION JUNCTIONS C E A SYSTEM

FOR CRYOGENIC, VACUUM, NUCLEAR AND SPACE APPLICATIONS

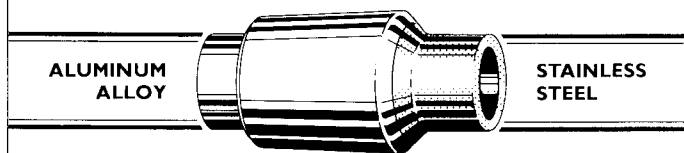

**THEY HAVE THE
SAME MECHANICAL
CHARACTERISTICS
AS THE ALUMINUM
TUBE AND CAN ALSO
BE FABRICATED
TO ANY MATERIAL
SPECIFICATIONS**

**TOTALLY RELIABLE BIMETALIC
TRANSITION JUNCTIONS
FOR TUBULAR ASSEMBLIES**
UP TO Ø 600 MM (24")
10⁻⁹ atm. cm³. S⁻¹
10 M Pa
0 to 573 K
UNDER RADIATION

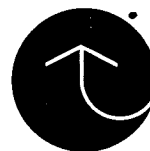

* COMMISSARIAT A L'ENERGIE ATOMIQUE

CALL OR WRITE FOR DOCUMENTATION

**THEVENET CLERJOUNIE ■ DEPARTEMENT JONCTIONS TC
CONTACT: M. ARMAND PINET, CONSULTING ENGINEER
22, AVENUE FRANKLIN-ROOSEVELT ■ 69517 VAULX-EN-VELIN
CEDEX FRANCE ■ TELEPHONE: (7) 849.54.64 ■ TELEX 380 544 F**

E. LOTTI sa Fondation 1808

**Réactifs de laboratoire
(Analyse - Synthèse - Biologie etc.)
Produits chimiques industriels**

Distributeur agréé de

Fluka Chimie Fine

Société mondialement connue

Gamme très complète de produits inorganiques et organiques de haute qualité.
Prix très compétitifs avec de plus des rabais de quantité.

Spécialités: Dérivés de Silicium - Chélatés - Catalyseurs, etc.

Ventron Alfa Products

Research chemicals and Materials

Organics
Inorganics
Organo Metallic
Analytical standards
Pure Metals and Alloys
Research grade gases
Electronic grade chemicals
Materials

E. LOTTI sa

Tel. 022 42 57 65 66
Telex 429 382 Lott CH
Telegramme LOTCHIM

We are manufacturers of purpose built vee clamps, specially produced in a range of materials to suit various strengths, temperatures, weights or corrosive resistant characteristics.

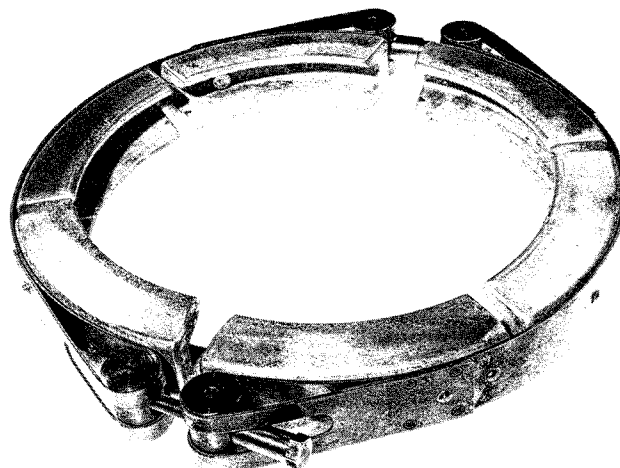

Illustrated is a heavy duty stainless steel and aluminium vacuum chamber vee clamp supplied by Smith & Johnson (Keighley) Limited to CERN.

Smith & Johnson (Keighley) Limited

Goulbourne Street, Keighley, Yorkshire, BD21 1PJ
Telephone (0535) 665181/2/3/4 • Telex 517420
• Fax (0535) 665185

Collaboration between the German firm Hans Wiener and CERN in the development of switching power supplies such as this quickly led to other power supplies for industrial applications.

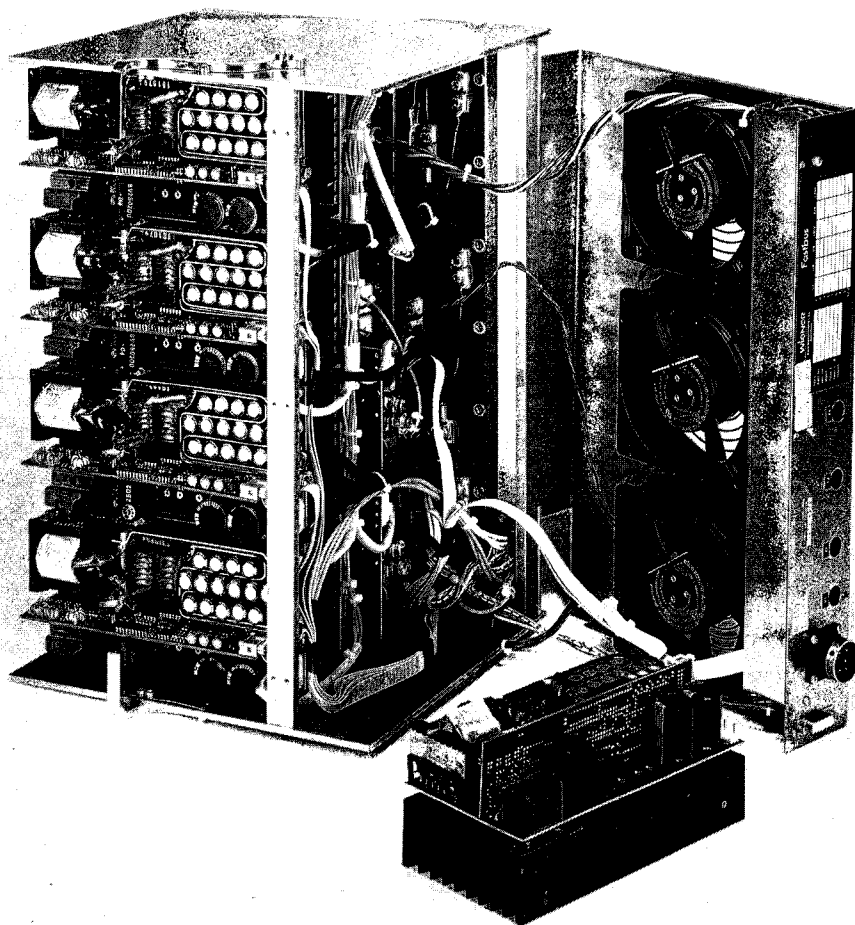

Electronics development with industry

As highlighted in the special November 1988 issue of the *CERN Courier*, the role of high energy physics as a catalyst for industry is becoming increasingly important. In the wake of stringent demands for size, performance, precision, high data rates, etc., technology is pushed to new limits, and spinoff benefits from the resultant new expertise are frequently quick to follow.

Playing a special role in this industrial collaboration is the Test and Instrumentation Group of CERN's Experimental Physics Division, taking care of manufacturing development, and prototype and production testing for new electronics equipment, together with the maintenance of a pool of 38,000 electronics instruments for physics needs.

As new requirements emerge, manufacturers are invited to tender on the basis of specifications drawn up by CERN. Development work is done partially at CERN,

where specialists from industry are free to work in an equipped laboratory reserved for the purpose, and manufacturers can benefit from the availability at CERN of sophisticated instruments such as high speed transient recorders, automatic test registers, fast digitizers, and climatic chambers.

Projects include fast electronics for NIM and Camac systems (CAEN, Italy), high and low voltage supplies (Novelec, France; and CAEN), and crates for NIM, Camac, Fastbus, and more recently VME modules (Grenson, UK; WES, Wiener, Germany; Pulsar, Italy; OSL, France). Fastbus supplies are particularly in demand for new physics experiments.

Recent examples of joint development projects include a multi-channel analyser (Silena, Italy), a programmable logic unit (CAEN) and a switching supply for use with Camac (WES, Wiener). In this way European industry is stimulated to compete with other world markets.

New route to electron emission

A new type of electron beam source is under development by a CERN/Katowice/Saloniki team looking at ferroelectric crystals (such as barium titanate) or ceramics (such as PLZT) whose tiny unit cell dipoles line up to provide a strong electric polarization field. This gives unpaired positive and negative electric charges on opposite faces of the crystal, normally masked by screening effects, but the team has shown that if the polarization direction is rapidly switched using high voltage pulses, the screening has no time to get

In the control room of the new BEPC Beijing Electron-Positron Collider at the Institute of High Energy Physics – left to right, former Institute Director Ye Minghan, new Director Fang Shouxian and Vice-Director Chen Shengyu.

established and local excess surface charges can attain a theoretical limit of 1 Cb per sq. m.

With nothing holding them back, electrons are expelled and accelerated from the surface by themselves – neither heating (thermionic effect), nor illumination (photoeffect), nor external extraction fields are needed and primary into beam energy conversion efficiency is between 1 and 10%! Beam characteristics can be controlled within wide limits by the type of material, its geometry and the applied high voltage pulses as well as by external fields. These electron beams have been reproducibly generated in two different experimental setups.

Provided switching times can be shortened to the subnanosecond range, the new source may readily meet the requirements of high intensity beam sources for possible new multi-TeV linacs. Another application at CERN is the development of an electron-beam-triggered high power switch. The availability of high power electron beams could also go on to make a sub-

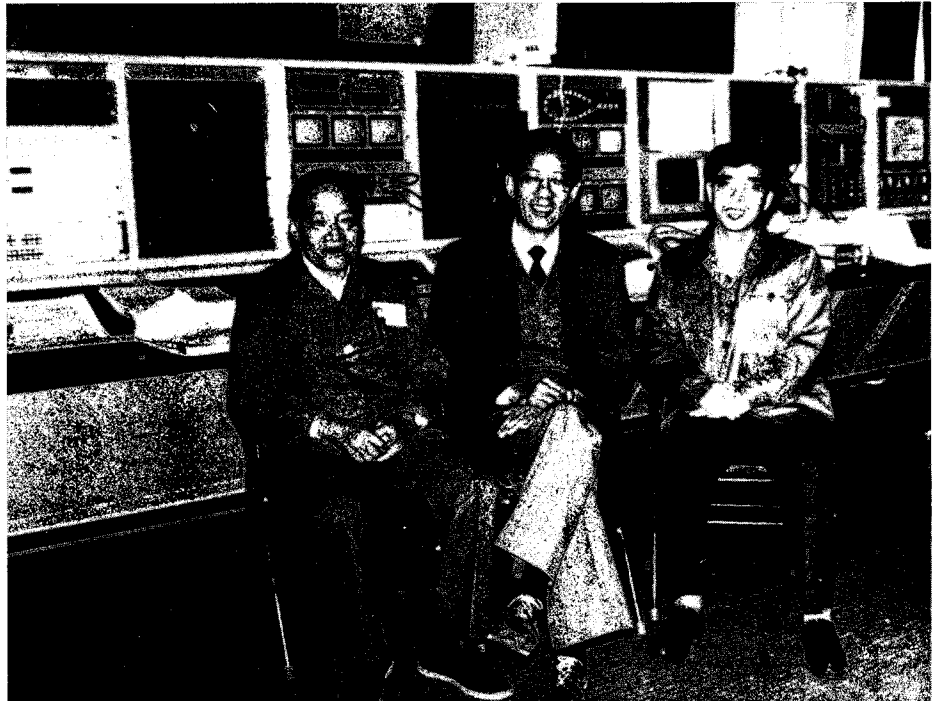

stantial impact in industry, and ferroelectric electron emission induced by the impact of high energy particles may also be of interest for fast, high resolution particle detectors.

including Deng Xiaoping, visited the centre on 24 October, just after the first test tracks were recorded in the new Beijing Spectrometer.

The Directorate of the Beijing Institute of High Energy Physics (IHEP) has also been changed. The team under Director Ye Minghan, with Vice-Directors Xie Jialin, Fang Shouxian and Zhang Houyin, named in February 1984, has overseen the building of BEPC, its successful operation according to schedule and within the allocated budget of 240 million yuan (about 64 million US dollars). Ye Minghan and former Vice-Director Xie Jialin return to research at the institute. New Director is Fang Shouxian, while new Vice-Directors are Chen Shengyu (head of BEPC), Zheng Zhipeng (head of experimental high energy physics), Xu Shaowang (head of development and production), Li Dezhong (head of administration) and Ma Tongjun (head of general support).

Electron emission from a ferroelectric crystal. The upper trace shows three electron current pulses measured on a transparent grid charged to -20 (smallest negative pulse), -10 and 0 volts. The total emitted charge is 0.4 Cb/sq. m, about a third of the spontaneous polarization in the crystal. Vertical divisions represent 0.05A, horizontal divisions 200ns.

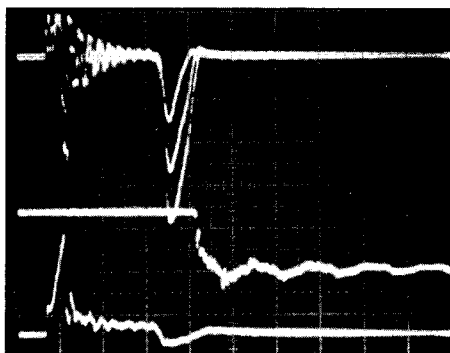

BEIJING Luminosity and people

Soon after the first electron-positron collisions were obtained in the 240 metre storage ring of the new BEPC Beijing Electron-Positron Collider (November issue, page 41), the 1.6 GeV beams attained a luminosity (a measure of the collision rate) of 8×10^{28} , with vacuum better than 10^{-9} torr. The next step is to boost the beam energy to above 2 GeV and the luminosity to 10^{31} ready for physics around the J/psi resonance.

A delegation of Chinese leaders,

Oak Ridge's Holifield tandem accelerator, 23.8 m high and with an active accelerating length of 16.5 m, has achieved a record terminal voltage of 25.5 MV.

In his inaugural speech, the new Director looked ahead to the exploitation of the new machine, calling for Institute staff 'to be united, democratic, hard-working and enterprising to build IHEP into a research institute of international standard'.

SOVIET UNION Applications of accelerators

Applications of the technologies emerging from particle physics have received extensive *CERN Courier* coverage in recent months, with examples from Laboratories in Western Europe, the USA and Japan. Impressive examples from the Soviet Union came in a talk at CERN by Igor Meshkov of the Institute of Nuclear Physics in Novosibirsk.

Novosibirsk has a history of providing accelerators for use in Soviet industry dating back to the 1960s and the inspired leadership of Gersh Budker. At present there are two powerful electron beam accelerators on the market each providing up to 2 MeV beam energy. One is a DC machine, called ELV, produced under R. Salminov; the other is a pulsed machine, called ILV, produced under V. Auslander. About eighty of these machines have been made. (A similar number of electron machines of different design have been produced at the Efremov Institute in Leningrad.)

Major applications are in radiation modification of polymers, polymerization, grain sterilization, and the cleaning of chemical contamination in cooling water. Appli-

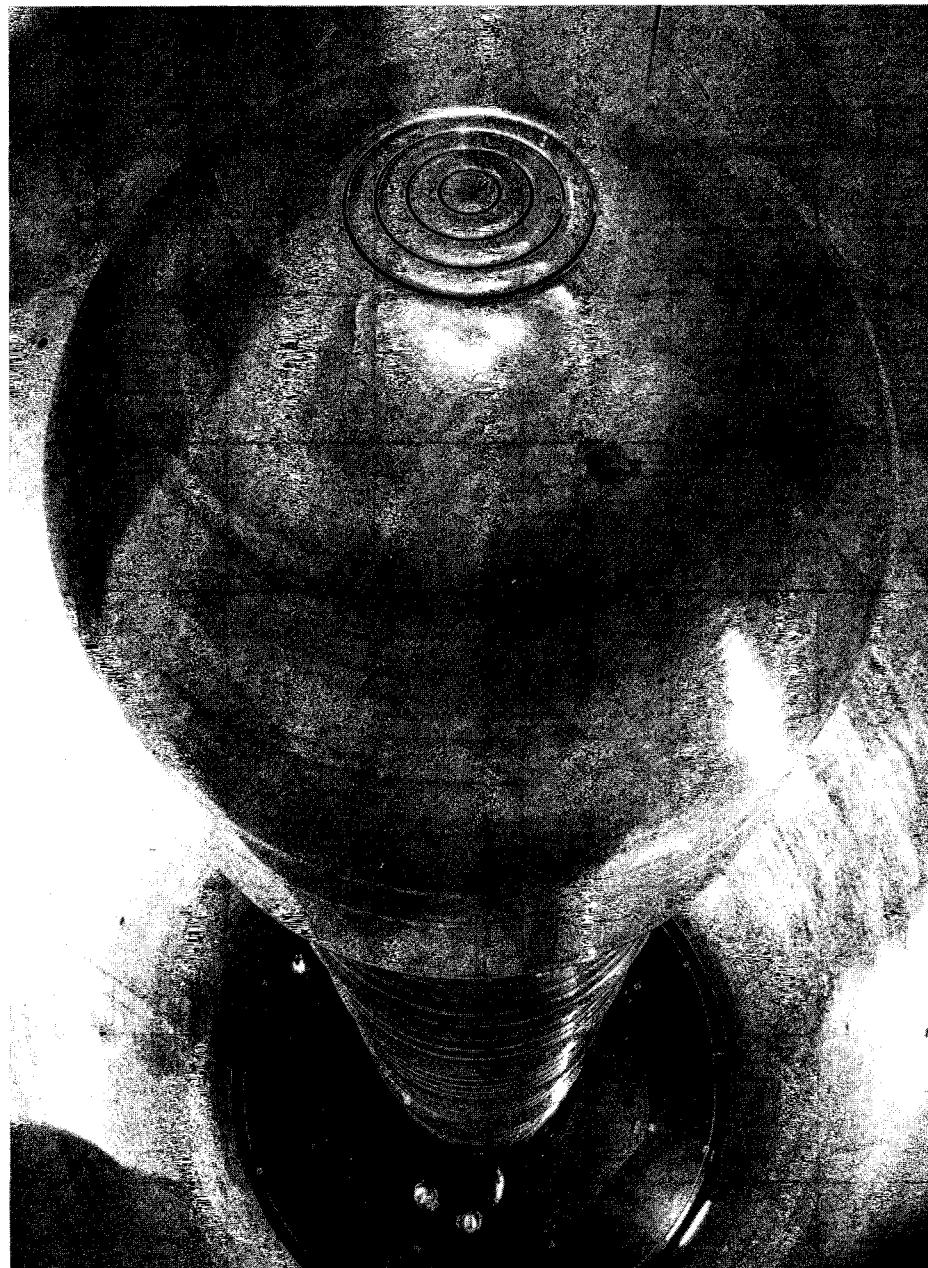

cations under development include the hardening of steel and iron, the superposition of a protective layer by diffusing other metal powders into steel, purification of gases, special melting and welding techniques, and the production of minute holes in ceramics for the electronics industry using 'needle' electron beams.

An ion beam machine of similar design, called LUI, has had its first tests and will be produced for industrial use in ion implantation and the fabrication of new materials.

To push the application of accelerator technologies a Centre of Physics Applications for Industry has been set up at Lipetsk. This is in association with the Novosibirsk-Serpukhov project aiming for electron linear colliders providing multi-

TeV (thousands of GeV) energies (January/February 1988, page 3). A recent innovation is a course on particle beam technologies being given at the Lipetsk Polytechnic Institute.

OAK RIDGE 25.5 megavolts

Last September, the Holifield Heavy Ion Research Facility tandem accelerator at Oak Ridge achieved a world record terminal voltage of 25.5 MV, and operated for an experiment at 25 MV.

The improved voltage results primarily from the installation of 'compressed geometry' acceleration

One of the many hazards proton beams have encountered.

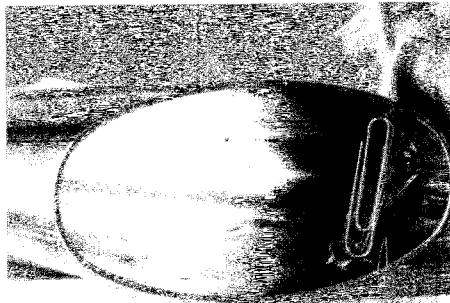

tubes, the components used in the original tubes having been reconfigured to increase the ratio of insulator length to total acceleration length by 17%.

Used alone and as an injector for Oak Ridge's Isochronous Cyclotron, the Holifield tandem plays an important role in the Laboratory's wide range of atomic and nuclear physics studies. It would also inject into the HISTRAP heavy ion synchrotron, storage ring and cooler proposed for Oak Ridge.

ACCELERATORS

A fast clip

Many particle physics Laboratories around the world have new machines, both large and small, under construction and which, like CERN's LEP electron-positron collider, should soon be ready for

commissioning.

Thus the recent course 'Observation, Diagnosis and Correction of Particle Beams', organized by the Joint US-CERN Particle Accelerator School in Capri, Italy, from 20-26 October received enthusiastic support.

The successful commissioning and operation of a new machine requires a blend of good technology for instrumentation, experience for interpretation, and theory for correction strategies. In this work the human element is very important, as illustrated by Gus Voss of DESY using several anecdotes.

He recalled how many years ago the beam at CERN's PS proton synchrotron was mysteriously lost in mid-ramp. By careful beam steering, the offending obstruction was located and the vacuum chamber opened to reveal a paper clip, which had been rising in the magnetic field, eventually interrupting the beam.

Apparently a sample of some now-forgotten material had been prepared for some equally forgotten tests inside the PS vacuum chamber. The sheet of paper pinned to the sample simply said 'Put this in the vacuum chamber - H.G. Hereward', and such was the awe inspired by this name that the ord-

A good turnout for the Joint US-CERN Particle Accelerator School course at Capri.

er was carried out precisely!

The CERN Accelerator School now turns its attention to its next course, Synchrotron Radiation and Free Electron Lasers, to be held in Chester, UK, from 6-13 April. Further details from Mrs. S. von Wartburg, LEP Division, CERN, 1211 Geneva 23, or bitnet CASDARS at CERNVM.

DARMSTADT

Christoph Schmelzer

80

On 24 November, after an event at the GSI (Gesellschaft für Schwerionenforschung) Laboratory, Darmstadt, to mark his 80th birthday, Christoph Schmelzer pushed the button to inject nuclear particles through a new transfer line into GSI's new SIS heavy ion synchrotron (October 1988 issue, page 27), scheduled for commissioning from April. In this way he was able to span two generations of GSI operations - from 1976, his UNILAC (Universal Linear Accelerator) has provided a complete range of nuclear particle beams for experiments. (The other stage of GSI's new installations, the ESR experimental storage ring, should be commissioned in 1990.)

At the GSI ceremony, Schmelzer was welcomed by Paul Kienle, and CERN Council President Josef Rembser brought greetings from the German Ministry of Research and Technology, reading from a letter from Minister Heinz Riesenhuber. Other speakers underlined Schmelzer's pioneer contributions to GSI and his role as a scientist and lecturer.

Before founding GSI and becoming its first Director, Schmelzer



FIVE YEAR FELLOWSHIP IN NUCLEAR PHYSICS

LAWRENCE BERKELEY LABORATORY'S Nuclear Science Division has a position open as Divisional Fellow for a person with outstanding promise and creative ability and an interest in experimental heavy-ion nuclear physics.

The central focus of the Division's research program is the production and study of nuclear matter at extreme conditions; specific programs including: the investigation of heavy-ion collisions at low, medium and very high incident energies; nuclear structure studies, production and characterization of exotic nuclei and nuclear astrophysics.

This research is carried out at LBL's Bevalac and 88-inch Cyclotron accelerators and accelerators at other laboratories. Instrumentation development is an integral part of the research program; for example, a TPC now under construction is expected to provide significant new research opportunities at the Bevalac.

Candidates with a background in either nuclear or high-energy physics or nuclear chemistry are welcome. The appointment will be for a term of five years with the intention of promotion to a senior staff position.

Applicants are requested to submit a curriculum vita, list of publications, statement of research interest, and the names of three references (Specify Job B/5015), as early as possible and before the closing date of March 31, 1989, to: **T.J.M. Symons, Director, Nuclear Science Division, c/o Employment Office, 90-1042, #1 Cyclotron Road, Berkeley, CA 94720.** We are an equal opportunity employer, M/F/H.



LAWRENCE
BERKELEY
LABORATORY



TRIUMF

MESON RESEARCH FACILITY

University of Alberta
Simon Fraser University
University of Victoria
University of British Columbia
Competition # 580-118

RADIO-FREQUENCY ENGINEER

TRIUMF requires a Radio-Frequency Engineer for design and development of rf systems. The work involves both the upgrading of existing systems and the creation of new apparatus, with strong emphasis on system reliability.

These systems cover the range from less than 100 watts to 1800 kW rf power output in the frequency range of 11.5 to 92 MHz. All systems are highly regulated in voltage, frequency, and phase by means of high-performance control systems.

Experience with high-power vacuum-tube amplifiers, as well as solid-state amplifiers is required. In addition, familiarity with cavity resonators and precision control systems (both analog and digital) is necessary.

Minimum requirements are a degree in Electrical Engineering and at least five years' related experience in a large research or industry environment.

Please reply in writing, outlining qualifications and experience, with names of three referees to: **TRIUMF Personnel (Competition 580), 4004 Wesbrook Mall, Vancouver, B.C., CANADA, V6T 2A3.**

Closing date for applications is **February 28, 1989.**

We offer equal employment opportunities to qualified male and female applicants.

DIRECTOR

Fermi National Accelerator Laboratory



The Fermilab Board of Overseers of Universities Research Association, Inc., (URA) has initiated a search for a new Director of the Fermi National Accelerator Laboratory. The position will be available July 1, 1989. The Search Committee is now in the process of assembling a list of suitable candidates and welcomes applications and nominations from the community of high energy physicists. Communications and resumes, which must be received by February 15, 1989, should be sent to:

Dr. Harold K. Ticho, Chairman
Search Committee
Universities Research Association, Inc.
Suite 400
1111 19th Street, N.W.
Washington, D.C. 20036

URA is an affirmative action/equal opportunity employer.

UNIVERSITY OF SOUTH CAROLINA

Faculty Positions in HIGH ENERGY PHYSICS

The Department of Physics at the University of South Carolina invites applications for two tenure-track positions in the area of experimental high energy physics. The positions are at the assistant professor level although appointment at a higher level may be considered for an exceptionally qualified candidate. The South Carolina high energy group currently pursues $e^+ e^-$ collider physics at KEK's TRISTAN ring using the AMY detector and an experiment on charmless two-body B^0 decays at Fermilab. The ongoing programs would welcome new members, but candidates with other research interests will also be considered. Applicants should submit a curriculum vitae and publications list, a statement of research interests, and the names of professional references to

**Prof. Frank T. Avignone,
III, Chairman,
Department of Physics and
Astronomy
University of South Carolina
Columbia, SC 29208**

The University of South Carolina is an Affirmative Action / Equal Opportunity employer and solicits applications especially from qualified women and minorities.

The outer cylindrical shell of the liquid argon calorimeter slides into the magnet coil of the SLD detector at Stanford prior to insertion of another, smaller, shell and then the calorimeter itself (see below).

played an important role in the preparations at CERN for the PS proton synchrotron in the 1950s. In the 1960s he was Director of Heidelberg's Institute of Applied Physics, where he set up a study group to prepare the ground for the UNILAC.

STANFORD Final SLD assembly

Almost two years ago, 2500 tons of prefabricated steel pieces destined for the Stanford Linear Accelerator Center (SLAC) quietly entered San Francisco Bay aboard the ship Ruth Lykes. About six months later, a 100-ton 6-metre aluminium coil came trundling through Palo Alto on a special truck, headed for the same destination.

By early 1988 the coil and hundreds of steel parts had been assembled into two arches, a barrel and two endcaps, making a fairly complete detector shell for SLD, a new, state-of-the-art detector being built for the SLC Stanford Linear Collider. Final assembly has now begun of the separate components inside this shell.

Last year the endcaps were closed on the barrel to complete the iron yoke for SLD magnet tests – the 6-kilogauss field was found to be more uniform than expected. The aluminum coil, powered by 6600 amps at 5 megawatts, encloses all the inner components of

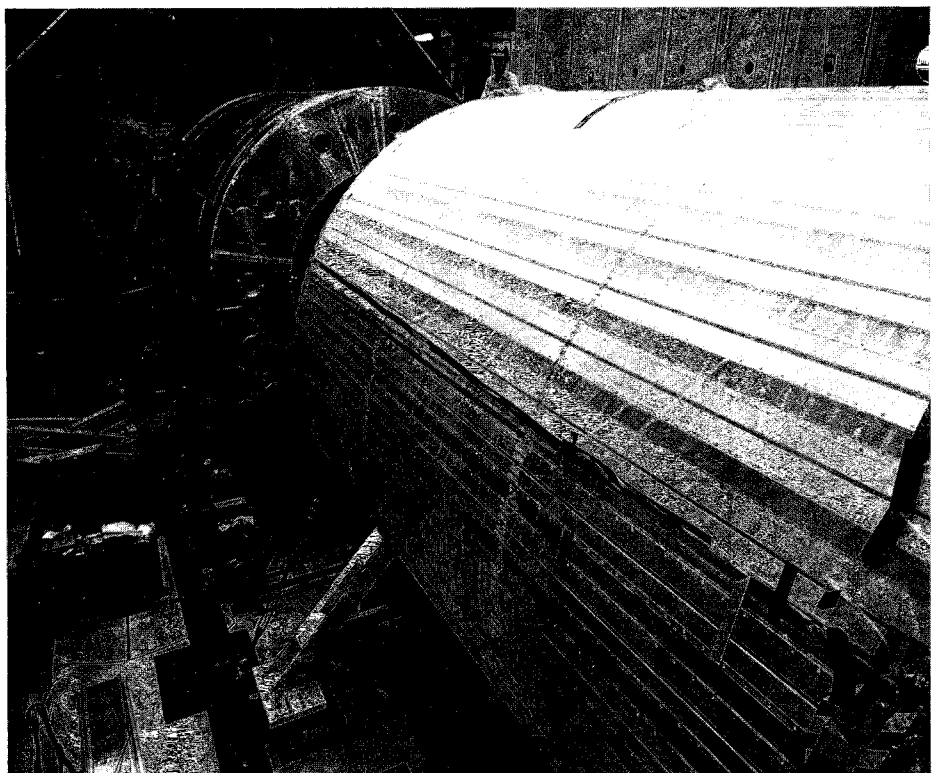
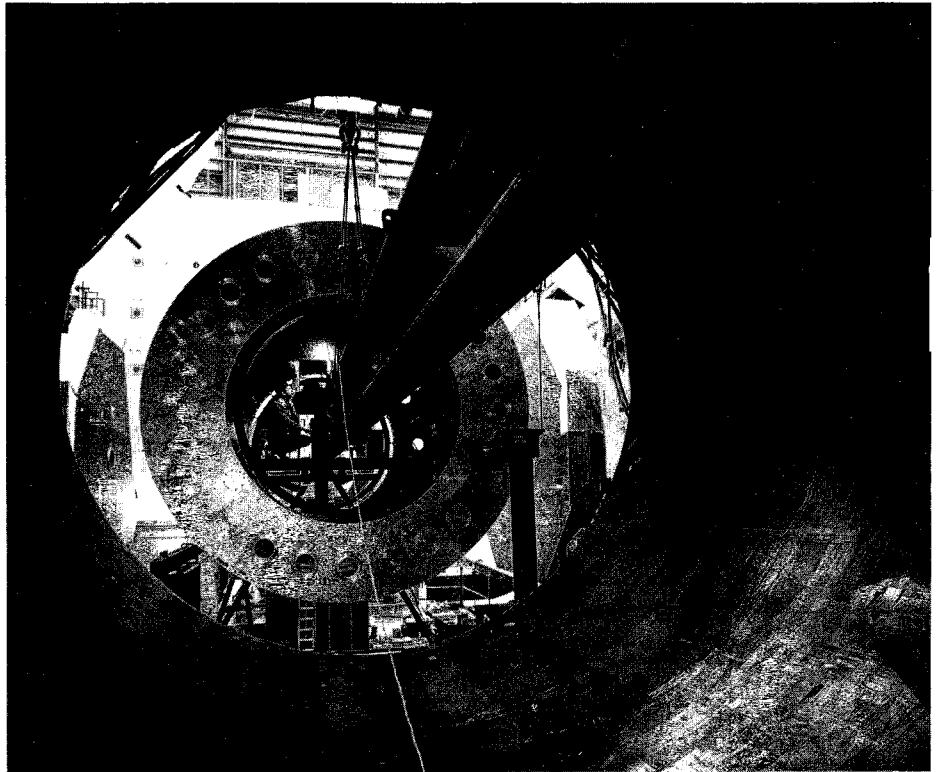

In the SLD pit, the liquid argon calorimeter (foreground) and its outer jacket await insertion into the SLD magnet yoke (rear).

(Photos SLAC)

People and things

the detector so as not to interfere with the detection of particles produced in SLC's electron-positron collisions.

Each section of the octagonal steel barrel surrounding the coil is a weld-up of fourteen 5 cm-thick steel plates with 2.5 cm gaps, each filled with flat limited-streamer chambers to detect penetrating muons and measure remnants of showers from the large liquid argon calorimeter. This system together with analogous components in the two endcaps has already been installed.

Once the large liquid argon calorimeter is completely installed by spring, the cylindrical shell of the Cherenkov ring-imaging detector slides in, followed by the 2-metre diameter central drift chamber. The innermost detection system is the vertex detector, two cylindrical layers of charge-coupled devices (CCDs) about the size of a tin can.

The SLD collaboration, composed of over 200 physicists and engineers from SLAC and 30 research centres in the United States, Italy, Canada, the UK, and Japan, expects to complete the detector by the end of 1989.

During his recent trip, the distinguished Soviet physicist Andrei Sakharov (centre) stopped off in Paris, where his engagements included an informal meeting with some members of the French Academy of Sciences. Left, with their backs to the camera, are mathematician Henri Cartan and physicist Yuri Orlov. Right, mathematician Laurent Schwartz (seated), and physicist André Guinier. The woman on Sakharov's right is an interpreter.

(Photo André Martin)

USSR Academy of Sciences

The USSR Academy of Sciences has elected CERN Director General Carlo Rubbia, together with Sam Ting, leader of the L3 experiment for CERN's new LEP electron-positron collider, Wolfgang ('Pief') Panofsky, former Director of SLAC, and Zhou Guangzhao, Director of the Academia Sinica, Beijing, as Foreign Members.

Honours for Schopper.

Former CERN Director General Herwig Schopper has been awarded an honorary doctorate by Moscow State University for 'outstanding contributions to the development of high energy physics and furthering the cooperation between the USSR and CERN...'

At the conclusion of the December session of the CERN Council

(below and page 1), Council President Josef Rembser announced that Federal German President Richard von Weizsäcker had awarded Schopper the Commander's Cross of the Order of Merit of the Federal Republic of Germany (Grosses Verdienstkreuz des Verdienstordens der Bundesrepublik Deutschland).

CERN elections and appointments

At its meeting in December, CERN Council elected Arnfinn Graue (Norway) as Chairman of Finance Committee, replacing Jan Bezemer (Netherlands). Georges Vianès (France) was appointed Director of Administration for three years, while André Naudi was appointed Head of Finance Division and David Williams as Head of Data Handling Division, both for one year, succeeding Marcel Lazanski and Paolo Zanello respectively.



ACCELERATOR SCIENTISTS AND ENGINEERS

Argonne National Laboratory will be entering the construction phase of its 7-GeV Advanced Photon Source (APS) Project. The APS is a state-of-the-art synchrotron x-ray source optimized to produce insertion-device radiation. APS accelerator facilities comprise a 7-GeV low-emittance positron storage ring 1100 m in circumference, a 7-GeV synchrotron, a 450-MeV positron accumulator ring, a 450-MeV positron linac, and a 200-MeV electron linac. The challenges of building the facility offer great potential for professional growth for scientists and engineers in the following areas:

ACCELERATOR SCIENTISTS

Several positions at various appointment levels are available for candidate with experience and interest in accelerator design, including computer simulation of beam dynamics, calculation of coupling impedance and collective effects, particle tracking simulation, lattice design, vacuum and surface physics, beam diagnostics, and magnetics and magnet design. Appointment level will depend on the candidate's experience. Entry-level or postdoctoral positions will be available.

ELECTRICAL ENGINEERS

Two senior positions are available, requiring an advanced engineering degree and at least ten years' experience in design and construction of large particle accelerators. Work experience in accelerator-type magnets and/or power supplies is highly desirable. We also have several positions requiring BSEE and a minimum of five years' experience in the following areas:

- Design and power electronics
- Multi-kilowatt power supplies
- Low-level fast electronics
- Beam diagnostics.

MECHANICAL ENGINEERS

A senior-level position is available, requiring an advanced ME degree at least ten years' experience in mechanical engineering aspects, such as ultra-high vacuum and structural design, of the design and construction of large particle accelerators. We also have several openings requiring a BSME and a minimum of five years' experience in the following areas:

- Survey and alignment techniques
- Ultra-high vacuum systems
- Mechanical design of magnets
- Shop fabrication practices.

You will receive a competitive salary and a superior benefits package which includes medical/dental insurance, 9% contribution to your retirement annuity, 24 days paid vacation, and 10 paid holidays each year. Please forward your resume in confidence to:

R.A. JOHNS, Appointment Officer
Box J-APS-88, Employment and Placement
ARGONNE NATIONAL LABORATORY
9700 South Cass Avenue
USA - ARGONNE IL 60 439



Argonne is an equal opportunity/affirmative action employer.

UNIVERSITY OF VIRGINIA EXPERIMENTAL HIGH ENERGY PHYSICS

SENIOR PROFESSOR POSITION

The Department of Physics at the University of Virginia is seeking qualified applicants for a tenured position at the associate or full professor level for an experimental high energy physics group now in the process of formation.

The selected individual would act as deputy head of the group.

This group has a major involvement at Fermilab in heavy flavor physics in experiment E705 and in beauty physics in experiment E771.

They also have a strong interest in future beauty physics options at both Fermilab and/or the SSC.

Candidates should have compatible research interests.

Interested parties should submit a resume and the names of at least three references to:

Professor Michael Fowler, Chairman
Department of Physics
J.W. Beams Laboratory of Physics
University of Virginia
McCormick Road
Charlottesville, Virginia 22901

Phone: 804/924-3781

The University of Virginia is an equal opportunity employer.

MECHANICAL ENGINEER

Laboratory For Nuclear Science

M.I.T.'s Bates Linear Accelerator Center is looking for someone to be responsible for coordinating the design, fabrication, and installation of magnetic, vacuum, and instrumentation hardware associated with a 1 GeV Pulse Stretcher Ring. Will document detailed mechanical design and analysis of the various systems components to verify their integrity and pre-operational checkout. Prepare mechanical layouts and detailed engineering designs for ultra-high vacuum systems, magnetic elements, various beamline instruments, support structures, etc. Set up test programs and quality assurance procedures to verify satisfactory designs and fabrications.

Requirements: B.S. in Mechanical Engineering or related field with a minimum of five years of experience. Must have knowledge of modern computerized design techniques, drafting, machine shop, and welding practices. Preference will be given to individuals with direct experience in accelerator technology. Experience with cryogenics and/or superconducting devices is desirable. M.I.T. is a non-smoking environment.

Interested candidates should forward two copies of both resume and cover letter, referencing Job #R88-228 to: Mr. Richard Adams, c/o M.I.T. Personnel Office, 400 Main St. (Bldg. E19-239), Cambridge, MA 02139.

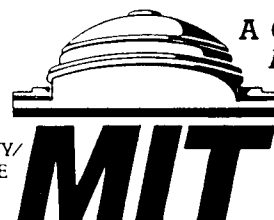

**A COMMUNITY
AT WORK**

M.I.T. IS
AN EQUAL
OPPORTUNITY/
AFFIRMATIVE
ACTION
EMPLOYER

A recent seminar at the Joint Institute for Nuclear Research, Dubna, near Moscow, marked the 60th birthday of distinguished Soviet theoretician Samoil Mikhelevitch Bilenky, who spoke on 'Future experiments on solar neutrino detection and problems of neutrino oscillations'.



Neutrino line-up: above, the Brookhaven/Columbia neutrino experiment group pictured in 1962, and below 26 years later in Stockholm when Leon Lederman, Mel Schwartz and Jack Steinberger received the 1988 Nobel physics prize. Left to right; Jack Steinberger, Dino Goulianos, Jean-Marc Gaillard, Nariman Mistry, Gordon Danby, Warner Hayes (missing in 1988 picture), Leon Lederman, Mel Schwartz.



Dubna reshuffle

In new senior staff appointments at the Joint Institute for Nuclear Research (JINR), Dubna, near Moscow, V.G. Kadyshevsky has been elected Director of JINR's Laboratory of Theoretical Physics, T. Vylay (Bulgaria) Director of the Laboratory of Nuclear Problems, Yu. Oganessian Director of the Laboratory of Nuclear Reactions, and N.N. Govorun Director of Computing Techniques and Automation. I. Savin is Director of a new Laboratory set up to handle particle physics experiments at accelerators elsewhere (such as CERN and the Institute of High Energy Physics, Serpukhov).



(Photo M. Jacob)

Jointly organized by CERN and UNESCO, a memorial meeting at CERN in November honoured Isidor Rabi, who played a seminal role in the foundation of CERN and who died last January. The speakers were (left), Norman Ramsey of Harvard, a former research colleague of Rabi, and UNESCO Director General Federico Mayor Zaragoza. It was at a UNESCO meeting in Florence in 1950 that Rabi had proposed the idea which eventually led to the creation of CERN.

(Photo CERN 554.11.88)



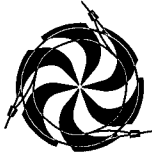

TRIUMF

MESON RESEARCH FACILITY

University of Alberta
Simon Fraser University
University of Victoria
University of British Columbia

RESEARCH ASSOCIATE POSITION

A Research Associate is sought for a two-year position at the University of Victoria Physics Department and TRIUMF. The post will be with the Particle Physics group currently engaged in installing and calibrating the SLD barrel liquid argon calorimeter. The work will be primarily a study of liquid ionization detector response to highly ionizing radiation. The existing programme includes experiments at Victoria and TRIUMF on the electron yield of 2,2,4,4 TMP and liquid argon as a function of deposited energy density. The results will be used to model the response of calorimeters to hadronic and electromagnetic showers.

Candidates should have a Ph. D. in Particle or Nuclear Physics within the past three years and have experience with radiation detectors and associated electronics. Salary will depend on experience, with a minimum of \$ 27,000.00 per annum.

Curriculum vitae, list of publications and names of three referees should be forwarded to: **Dr. R. Keeler, Department of Physics, University of Victoria, Victoria, B.C. CANADA V8W 2Y2.**

Applications will be accepted until **March 15, 1989.**

We offer equal employment opportunities to qualified male and female applicants.

GEODESIST

Fermi National Accelerator Laboratory, a high energy physics accelerator research facility located 40 miles west of Chicago, Illinois, is seeking an analytical professional to supervise the development of field procedures and applications programs for "microgeodesy" and industrial alignment.

To qualify, you must have a Master's degree in geodetic science or photogrammetry with an emphasis on surveying science and statistical analysis. Minimum 2 years management experience and excellent verbal and report-writing skills are required. Computer programming ability and industrial alignment background are highly desirable.

Further your professional career in Fermi's dynamic atmosphere. We offer an attractive salary and benefits package. For consideration, please send your resume and salary history to:

Mr. James L. Thompson
Employment Manager
Fermi National Accelerator Laboratory
P.O. Box 500
Batavia, Illinois 60510 U.S.A.

An Equal Opportunity Employer M/F.

INDIANA UNIVERSITY

Faculty Position in ACCELERATOR PHYSICS

The Department of Physics at Indiana University-Bloomington invites applications for a tenure-track faculty position at the associate or full professor level in accelerator physics. The department is establishing a new graduate program in accelerator physics and is inviting applications from PhD physicists with extensive experience in the theory and practice of accelerator design who are interested in and capable of taking a leading role in building and guiding a strong academic and research program in accelerator physics. Responsibilities include developing and teaching an appropriate curriculum in accelerator physics and supervising graduate student research in accelerator physics at the Indiana University Cyclotron Facility or other major accelerator facilities. Indiana University is a major research institution with strong programs in accelerator-based nuclear and high energy particle physics and a 50-year history of forefront accelerator development and construction. Present facilities include a 200 MeV separated-sector cyclotron and a 500 MeV storage ring/synchrotron with electron cooling. Several senior faculty members in nuclear physics and IUCF staff members with experience in accelerator design will also be involved in the new accelerator physics program.

To apply please send a complete vita (including a description of research interests, accomplishments, and a list of publications), and arrange for a minimum of three letters of reference to be sent to

Professor J.M. Cameron
Department of Physics
Indiana University
Bloomington, IN 47405

Applications must be received by the closing date of February 15, 1989.

Indiana University is an Equal Opportunity/Affirmative Action Employer.

GANIL
GRAND ACCÉLÉRATEUR NATIONAL
D'IONS LOURDS
CAEN (FRANCE)

INGÉNIEUR THÉORICIEN D'ACCÉLÉRATEUR

Un poste est ouvert au GANIL pour le recrutement d'un ingénieur récemment sorti d'une grande école, ou ayant des diplômes universitaires équivalents. Nationalité française exigée. Statut des agents du Commissariat à l'Énergie Atomique (CEA).

Cet ingénieur sera intégré dans l'équipe chargée d'élaborer les projets de développement de l'accélérateur, à moyen et à long terme. Il sera aussi associé aux études à court terme entreprises pour l'amélioration des performances de l'accélérateur.

Adresser les candidatures avant le 1^{er} février au Secrétariat Général.

Adresse:

GANIL
B.P. 5027
14021 CAEN Cédex

Films and video material

To promote public awareness of particle physics, the International Committee for Future Accelerators (ICFA) has proposed that the CERN Courier could advertise from time to time the availability of new books, films and video material for non-specialist audiences.

New books are already widely advertised, film and video material less so. Suppliers or sources of such material are invited to send us details – title, summary, format, cost, etc. – for publication in a special CERN Courier slot. The CERN Courier will not itself act as a distribution centre for this material.

DESY people

Ludwig Baumgarten, Division Leader at the German Ministry of Research, has been nominated Chairman of the DESY Administrative Council, taking over from Josef Rembser, now President of CERN Council.

Roberto Peccei, speaker of the DESY Theory Group since 1984, has left DESY for UCLA.

Cesar Lattes of the Centro Brasileiro de Pesquisas Físicas, Rio de Janeiro, was awarded the 1987 Physics Award of the Third World Academy of Sciences for his fundamental contributions to high energy physics and in particular for his role in the discovery of natural and artificial mesons.

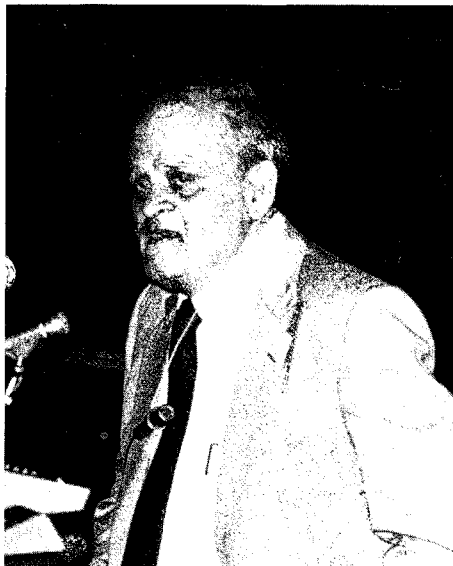

Rio de Janeiro

In November, Brazilian physicists celebrated the 70th birthday of J. Leite Lopez, Director of the Centro Brasileiro de Pesquisas Físicas (CBPF-Brazilian Centre for Physics Research), Rio de Janeiro. As well as his pioneer work on field theory and particle physics in Brazil, he is well known for his contributions to weak interaction physics.

Theorist Guido Beck of CBPF died on 21 October following a car accident. Author of significant papers in theoretical and nuclear physics, he came to Brazil in 1953 and had helped develop a whole generation of Brazilian physicists.

Chinese ions

The Lanzhou K450 heavy ion cyclotron has given an extracted beam of 50 MeV/N carbon 6^+ ions.

Yuri Orlov, at Cornell since 1987, is spending a year in CERN's PS Division.



Luigi Bernerdi Rossi (right), President of the Italian Consiglio Nazionale delle Ricerche (CNR), receives a souvenir tankard from David Gray at the UK Rutherford Appleton Laboratory following the inauguration of the PRISMA spectrometer at the Laboratory's ISIS pulsed neutron source. The result of a six-year Anglo-Italian collaboration and built at the CNR's Frascati Laboratories, the spectrometer (for measuring atomic vibrations) was installed at ISIS in November 1987.



ASSOCIATE LABORATORY DIRECTOR

Join Fermi National Accelerator Laboratory in our exciting achievements as a world leader of "High Energy Physics Research". We are seeking a dedicated Associate Laboratory Director to provide farsighted planning, coordination, and direction to various administrative support organizations of the Laboratory. Your responsibilities will also include major projects representing Fermilab and overall Laboratory budget planning and control.

A strong background in both technical and administration management of research and development is essential. An advanced degree in physics, engineering, or business administration is required. Prior exposure to high energy physics research or accelerator development is a plus. Familiarity with U.S. Department of Energy procedures and regulations as they apply to a National Laboratory engaged in Research and Development is a plus.

Located 48 kilometers west of Chicago, Illinois, our expansive 28 square kilometers of land are host to some of the most challenging and instrumental projects facing science today. Challenge your potential while you realize your utmost career expectations. We offer an excellent salary and benefits package. Please send your resume and salary history to:

Warren F. Cannon
Fermi National Accelerator Laboratory
P.O. Box 500
Batavia, Illinois, 60510 U.S.A.

An Equal Opportunity Employer M/F.

CENTRE DE PHYSIQUE DES PARTICULES DE MARSEILLE FACULTÉ DES SCIENCES DE LUMINY

INGÉNIEUR PHYSICIEN POSTE CNRS

- Participation, coordination, direction des réalisations techniques en instrumentation scientifique pour expériences haute énergie.
- Connaissances instrumentation, électronique et mécaniques appréciées, expérience dizaine d'années souhaitée.
- Niveau poste ajusté en fonction profil.
- Mutations d'EPST française examinées.
- Nationalité française non exigée.
- Lieu de travail: Marseille-Luminy. Domaine des Calanques.

CV. à: **A. d'Ancona**
CPPM case 907
Faculté des Sciences
de Luminy
13288 Marseille
cedex 09

EXPERIMENTAL HEAVY-ION PHYSICS RESEARCH POSITION AT LAWRENCE BERKELEY LABORATORY

The Lawrence Berkeley Laboratory's Nuclear Science Division has an opening for a Staff Physicist to participate in the HISS TPC (Heavy Ion Spectrometer System Time Projection Chamber) Project at the Bevalac. This is a two year appointment with the possibility of a career appointment.

Initial responsibilities involve the computer modeling required for design studies and the development of the software systems. Duties will include the planning of prototype tests and analyzing test results while investigating existing analysis software and developing software for use in the final TPC for calibration, signal processing and track reconstruction. The employee will be expected to participate in experiments using the detector and will contribute to the formulation and performance of the scientific program.

The successful candidate will have a Ph.D. in nuclear or particle physics as well as research experience in this area as evidenced by a record of recent publications, with extensive background using large detectors, computers and electronic equipment.

Applicants are requested to submit a curriculum vita, list of publications and the name of at least three references (Specify Job B/5003) to: **Dr. Hans-Georg Ritter, c/o Employment Office, #1 Cyclotron Road, 90-1042, Berkeley, CA 94720.** An equal opportunity employer, M/F/H.



Unsere UHV-Ventile werden weltweit für Anlagen mit höchsten Vakuumansprüchen (z.B. Beschleuniger, Speicherringe) eingesetzt.

Als PRODUKT MANAGER UHV-VENTILE

haben Sie vorzugsweise eine Ausbildung in Richtung Maschinenbau, sind ein Experimentalphysiker mit einem Flair für Mechanik, haben Freude am Kontakt mit Aussendienst und Kunden, oft in Englischer Sprache. Sie haben Spass, eine Produktgruppe kompetent zu führen und die Entwicklung dieser Ventile weiterzutreiben.

Wenn Sie an dieser vielseitigen Tätigkeit interessiert sind, richten Sie bitte Ihre Bewerbung an

Dr. R. Fischer
VAT AG,
CH-9469 Haag



LAWRENCE
BERKELEY
LABORATORY

Meetings

Jointly sponsored by Tel Aviv University and the Weizmann Institute of Science, the 9th International Conference 'Physics in Collision' will take place in the Kibbutz Ma'ale Hahamisha on the outskirts of Jerusalem from June 19-22. Information and invitations from the Chairman of the Organizing Committee, Jacob Grunhaus, School of Physics, Tel Aviv Univ., 69978 Tel Aviv, Israel, bitnet: Physcoll at TAUNIVM.

A Users' Meeting of the European Synchrotron Radiation Facility (ESRF) will be held in Grenoble from 20-23 March. ESRF construction began on 1 January 1988, and at least 7 experimental stations should be available in mid-1994, with 11 more the following year. Design work for the first stations should begin early next year. However it is already clear that there will be proposals for more than the total of 30 stations funded so far. The meeting will survey the needs of prospective users before deciding the priority order for building the stations. Further information from the Director General, ESRF, BP 220, 38043 Grenoble Cedex, France.

An Eloisatron Project Research Workshop 'Higgs Particle(s) - Physics Issues and Search Strategies in High Energy Collisions' will be held at the Ettore Majorana Centre, Erice, Sicily, from 15-26 July. Further information from Ahmed Ali, DESY (T), D-2000 Hamburg 52, bitnet IO2ALI at DHHDESY3.



Electron cooled heavy ions

On November 17 a beam of carbon-12 $6+$ ions at an energy of 73 MeV was successfully electron cooled at the Test Storage Ring TSR of the Max Planck Institut für Kernphysik in Heidelberg (September 1988, page 17). A stack of 1.5×10^9 particles with a momentum spread of 2% was cooled in less than a second to a final value of 0.017%. Coldest beam so far has had a spread of 2.3×10^{-5} .

2 December saw the dedication of Fermilab's new Feynman Computing Centre. Housing Digital Equipment VAX and Amdahl machines, together with the Advanced Computer Program microprocessor array. The distinctive building continues Fermilab's tradition of innovative, dramatic and practical architecture initiated by founding director Robert R. Wilson. Beyond, between the road and the synchrotron ring, can be seen the building housing the CDF proton-antiproton collider detector.

(Photo Fermilab)

▼ Participants at the 'Hadronic Matter in Collision' meeting held at Tucson, Arizona, from 6-12 October, sponsored by the University of Arizona, Tucson, and the US National Science Foundation.

(Photo Janet McCoy)





Inward bound in a new binding

Abraham Pais' admirable book 'Inward Bound – Of Matter and Forces in the Physical World', first published by Oxford University Press in 1986, is now also available in paperback. The main part of this book deals with the period 1895-1945, where the evolution of the science is followed in depth and the personalities nicely sketched. Pais never forgets that basic physics is the result of human endeavour. Especially poignant is his description of the early career of George Uhlenbeck, pioneer of electron spin with Samuel Goudsmit, and who died in November, age 87.

1988 Nobel prizewinner Jack Steinberger (left) was one of the speakers at an interdisciplinary symposium in Bologna in October celebrating the 70th birthday of the distinguished Italian physicist Giampietro Puppi (right).

(Photo P. Waloschek)

▲ 'Superstrings' and quantum chromodynamics, the emerging theory of inter-quark forces, were discussed last summer at a workshop at Nor-Amberd in Soviet Armenia organized by the Yerevan Physics Institute under the USSR-USA collaboration agreement in particle physics.

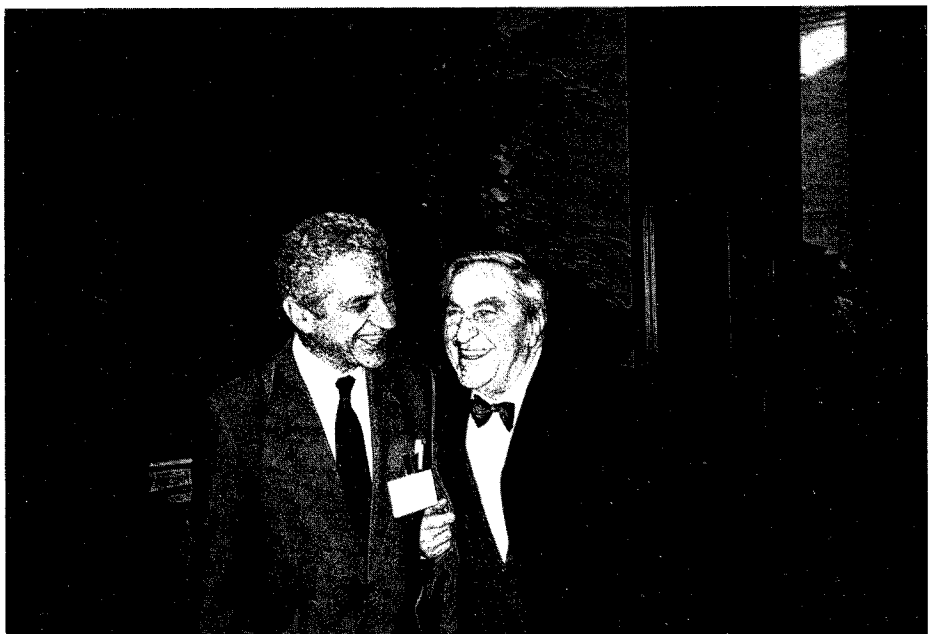

Erhard Fischer

On 13 November 1988 Erhard Fischer died from cancer. After joining CERN in 1958 he began basic R and D on ultrahigh vacuum problems for the proposed CESAR storage rings. When the Intersecting Storage Rings (ISR) project began in 1965 he became head of the Vacuum Group and under his leadership the limits of large ultrahigh vacuum systems were pushed to world records, eventually reaching 3×10^{-12} torr average pressure in a 2 km vacuum chamber, withstanding also the effects of large stored proton currents. His was a key contribution to the success of the ISR. In 1979 he moved across to become head of CERN's Training and Education Service where he introduced a popular scheme of management training. He retired in November 1986 after 28 years at CERN. Everybody who came in contact with him was attracted by his professional qualities and his deep human attitude.



Marcello Conversi (centre), with (left) Ettore Fiorini and Emilio Zavattini.

Marcello Conversi 1917-1988

Less than a year after his 70th birthday had been marked by a special seminar in Rome, the ingenious Italian experimenter Marcello Conversi died in September. He was best known for his historic cosmic ray experiment with Ettore Pancini and Oreste Piccioni in 1946 which showed that the 'mesotron' particle seen in cosmic rays did not behave like a strongly interacting nuclear particle, and had to be something very different.....

By the outbreak of the Second World War, Italian physics had been impoverished by the earlier departure of illustrious figures (Fermi, Segré, Pontecorvo, Rasetti, Rossi, Wick, Bernardini) and the premature death of Ettore Majorana. Of the celebrated Rome school of the 1930s, only Edoardo Amaldi remained.

Muted, the physics effort at Rome continued throughout the War, despite many great difficulties. In 1943 Conversi and his colleagues wisely decided to move their apparatus from the university campus to a site near the Vatican less subject to air raids.

With Gilberto Bernardini, he developed crude but effective magnetic lenses to separate positively and negatively charged cosmic ray particles, and in a pioneer application of microsecond electronics with Piccioni, he used 'delayed

coincidences' to correlate stopping particles with their decay products.

This work paralleled some of the pioneer studies being done elsewhere in the world, but unknown to the Italians in view of wartime communications problems. One such result was that some cosmic ray particles stopping in iron nevertheless underwent radioactive decay, with a lifetime of a few microseconds.

Switching from iron to graphite absorbers, the 1946 experiment dramatically showed that the negatively charged component of cosmic rays decayed radioactively rather than being captured by the graphite. The theories at the time held that the penetrating cosmic ray particles were the mesons postulated by Yukawa as the carriers of the strong nuclear force, suggesting that the negative particles should immediately be captured by nuclei without decaying. However the Rome experiment clearly showed that the negatively charged cosmic particles (what we now call muons) behaved very differently. Continuing the great tradition of Fermi, Italian physicists had written another page of weak interaction physics history.

Later his influential school, from 1950 at Pisa and from 1958 at Rome, produced many famous Italian particle physics names (among them Paolo Franzini, Marcello Cressi, Carlo Rubbia, Italo Mannelli and Luigi de Lella), and was a continual powerhouse of new ideas.

In the 1950s, with Adriano Gozzini, he introduced the flashtube idea, a precursor of the spark chamber, which went on to become a standard tool in particle and cosmic ray physics. In the early 1970s, he showed how the relatively delicate neon-filled glass flashtubes could be replaced by inexpensive extruded plastics, giving the technique a new lease of life.

At Pisa, he also founded what was then called the Centro Studi Calcolatrici Elettroniche, where CEP, the first Italian electronic computer, was built in the early 1950s. For this work he received the gold medal of the President of the Italian Republic in 1961.

At CERN, Conversi was a member of the Scientific Policy Committee from 1969-1975, becoming its Vice-President. From 1959, he participated in a series of quests at the SC synchro-cyclotron for 'forbidden' processes in weak interactions. When the new SPS proton synchrotron began operations in 1976, he played a prominent role in searches for short-lived particles using a stack of nuclear emulsion coupled to the BEBC bubble chamber.

Margarethe Krammer

Austrian theoretician Margarethe Krammer, well known at CERN, where she worked for several years in the mid-60s, and DESY, where she worked to 1984, died in her home town of Graz on October 27 after a long illness. She had worked mainly on the vector dominance model and on quark ideas, and was an excellent teacher and a sympathetic discussion partner for both experimentalists and theorists.

SPAIN AT CERN



Companies participating:

IGC

Ana Teresa, 13
28023 Aravaca, Madrid, Spain
T: 34-1-357 21 42

Service facilities:

Quality management, reliability and safety. Risks analysis, industrial control, industrial safety and artificial intelligence labs.

ABENGOA, S. A.

Avda. Carlos V, 20
41004 Sevilla, Spain
T: 34-54-42 20 11

Service facilities:

Control and distribution boards, MV switchgear, bus ducts and rectifier equipment, LV distribution boards, instalations in general.

CAE

Serrano, 27
28001 Madrid, Spain
T: 34-1-341 60 34

Service facilities:

- Industrial sector: advanced processing control, remote controls, online analysers, industrial computer technology, safety engineering, electric devices, instrumentation and mechanical devices, safety devices and maintenance of industrial plants.
- Administration services: urban and suburban traffic control, projects and instalations on lighting and environmental control.
- Defense: development of simulation software for defence and avionics, engineering and manufacturing of electronic equipment.

AMPER

Torrelaguna, 75
28027 Madrid, Spain
T: 34-1-404 36 00

Products:

Telephonic terminals and supplementary equipments, teleaction terminals, communications for companies, RDSI terminals, RDSI enterprise communications, telematics, data processing, network administration, mobile communications, data network commutation equipments, within each pack, intelligent public telephones.

FIBERTECNIC

Portal de Gamarra
01013 Vitoria, Spain
T: 34-45-27 91 00

Products:

Engineering, calculation and manufacturing of composites, using carbon fibers, aramide and

glass with the various kinds of resins, fibertecnic has specialized in semi-structural and structural parts.

TELESINCRO

Rocafort, 98-100
08015 Barcelona, Spain
T: 34-3-325 41 00

Products:

Payment authorizer, videotex terminals, transactional terminals with memory card. Portable payment terminals, micros, 100-500 W. power source, DC/DC converters.

TRATAMIENTOS TERMICOS

Ctra. de Elgueta, s/n.
20570 BERGARA, Guipúzcoa,
Spain
T: 34-43-16 48 44

Products:

- Thermic treatments: recocking, standarization, improvements, carbonituration, and nituration of parts, high-vacuum, treatments, controlled atmosphere and by induction, aluminium treatment and special alloys.
- Surface coatings: thermic projection by means of carbides and ceramics plasma, chemical nickel, P.T.F.E.

AGUT

Marqués de Comillas, 1
08225 TARRASA, Barcelona, Spain
T: 34-3-788 18 00

Products:

B.T. and M.T. contractors, thermic relays, starters, auxiliary and electronic relays control units, over-runners, proximity detectors, electronic regulation of engine speed, engine centres and control of distribution for B.T. and M.T.

SENER

Raimundo Fdez. Villaverde, 65-20
28003 Madrid, Spain
T: 34-4-463 64 00

Service facilities:

- Prospections in advance, surveys of feasibility and detail, purchase management and supervising of manufacturing, assembling and starting up.
- Sener engineers and supplies systems or components with a high technological content, subcontracting their manufacturing.

ENSA

Rosario Pino, 14-16
28020 Madrid, Spain
T: 34-1-435 30 46

Products:

- Specialized in the engineering, manufacturing, assembling, maintenance and fixing of primary components for nuclear plants.
- Quality control, laboratory, training and technical cooperation services related to its activity.
- Manufacturing of large, thick walled, conventional components.

GRUPO DYE

Llanos de Jerez, 8
28820 COSLADA, Madrid, Spain
T: 34-1-673 41 15

CTE. ELECTRONICA

Products:

- Marketing, instalation and post-sales service of emerson uninterruptep power systems.
- Engineering, manufacturing and post-sales service of: converters, rectificators, voltage stabilizers, engine starters for helicopters. Special (60, 400 Hz.) with military specifications unerrupted military power systems.

MASA

Products:

Ligth alloys, steel and titanium equipment (beams, coverings, ribs, ironworks, etc.) for aeronautical purposes.

Engineering and manufacturing of equipment, engineering surveys, manufacturing of terrestrial and aerospace antenn.

DYE

Products:

Large milling machines either alphanumerical controlled or equiped with copying system from 3 to 5 geometrical movements axes. S-shafted, high speed, alphanumerical controlled milling machines for compound materials, money comb, plastics, etc. Large vertical lathes tool rooms automation. Flexible manufacturing systems, special machinery.

INGOVI

Ctra. Directa a Aldaya, s/n.
46960 ALDAYA, Valencia, Spain
T: 34-6-150 13 62

Products:

Special machinery and industrial plants, engineering, manufacturing, mechanization and assembling in mechanisms, groups, mechanical transport and transmission sets, parts and spare parts in machinery and equipments.

LeCroy is a leader in high speed electronic measurement and data acquisition systems for scientific and industrial applications. Our Geneva division has gained world-wide reputation for designing, manufacturing and marketing high performance digital oscilloscopes.

To meet the requirements of a rapidly expanding market, we offer various challenging positions.

If you are interested in working in a fast expanding company, are physicist or electronic engineer with at least five years of relevant experience and are fluent in English and French, please contact our Personnel Department.

RESEARCH AND DEVELOPMENT

SR. ANALOG DESIGN ENGINEER

MARKETING

PRODUCT MANAGER

TECHNICAL WRITER

OPERATIONS

MANUFACTURING ENGINEER

EDP

ANALYST PROGRAMMER



LeCroy SA
101, route du Nant-d'Avril
CH-1217 Meyrin - Geneva
Phone 022/ 82 33 55

LeCroy

Innovators in Instrumentation

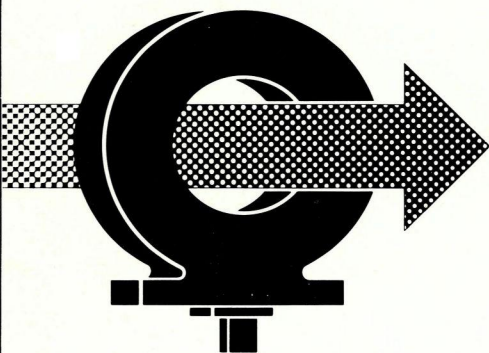

PEARSON

Wide Band, Precision

Current Monitor

With a Pearson current monitor and an oscilloscope you can make precise amplitude and waveshape measurement of ac and pulse currents from milliamperes to kiloamperes. Currents can be measured in any conductor or beam of charged particles, including those at very high voltage levels.

A typical model gives an amplitude accuracy of +1%, -0%, 20 nanosecond rise time, droop of 0.5% per millisecond, and a 3 db bandwidth of 1 Hz to 35 MHz. Other models feature 2 nanosecond rise time, or a droop as low as 1% per second.

Contact us and we will send you engineering data.

PEARSON ELECTRONICS, INC.
1860 Embarcadero Road, Palo Alto, Calif. 94303, U.S.A.
Telephone (415) 494-6444 · Telex 171-412 · FAX (415) 494-6716

PEP Modular Computers®

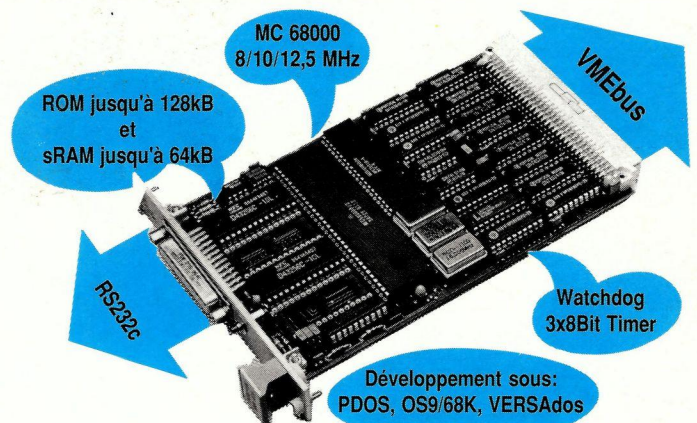

CPU de système CMOS pour des applications avantageuses à bus VME

VMPM68KA - 2 (8MHz), Prix: Fr. 890.-

Omni Ray SA, Industriestrasse 31, CH-8305 Dietlikon/Zurich

tél. 01/835 21 11

OmniRay

Tout ce qui a un avenir en technique.



Cryorefrigerators

The solution for a wide range of cooling problems

182.8.61.17.013.02 CD

LEYBOLD offers a wide range of cryorefrigerators for research and industrial purposes, covering the temperature range from 4 K to 330 K with closed-cycle helium refrigerators. These refrigerators are suitable for any application where liquid refrigerants are undesirable.

Typical applications include:

- Cooling of test specimens in cryostats, e.g. for high temperature superconductivity research
- Shield cooling of superconductive magnets
- Cooling of low-noise amplifiers and detectors
- Hydrogen liquefiers for H₂ targets

Our product line comprises 1,2 or 3-stage refrigerators with accessories, complete cryostats and - needless to say - cryopumps for all high or ultra high vacuum applications with pumping speeds between 400 l·s⁻¹ and 60,000 l·s⁻¹.



Detailed information on request!

LEYBOLD AG – A Degussa Company

LEYBOLD AG
 Oerlikonerstrasse 88
 CH-8057 Zürich
 Tel.: 01/311 57 57

LEYBOLD AG
 Bonner Strasse 498
 D-5000 Cologne 51